

UPDATE : 10/8/2015

**MUỐI LƯỚI INDEX**

Thuyết minh cách số đứng danh mức phụ tương

HOW TO USE THIS PART CATALOGUE

Các bộ phận cơ

CONTENTS - ENGINE GROUP

.....1

Các bộ phận khung sôđôn

CONTENTS - FRAME GROUP

.....4

Danh mức các phụ tương trong cơ

ENGINE PARTS CATALOGUE

.....7

Danh mức các phụ tương trong khung sôđôn

FRAME PARTS CATALOGUE

.....33

Bảng tra mã số phụ tương

PARTS INDEX

.....66

Bảng color chat

COLOR CHART

..... 71

**THUYẾT MINH CÁCH SỐ ĐỨNG DANH MỨC PHỤ TƯƠNG**

PHAÂN LOẠI MÃ SỐ PHỤ TƯƠNG

- 1. Bộ phận cơ
  - 2. Bộ phận khung sôđôn
- Qui cách mã số chi tiết

Ví dụ: Một nhóm bộ phận

00000 - 000 - 0000 - 00

Mã số bộ phận      Chuồng loại xe      Soá qui ðòuc xuaát Mã số cái bieán thieát

Ví dụ: Bulon, ñai oác vaø các phụ tương tiêu chuẩn khác

00000 - 00000 - 00

Mã số kích thước      Mã số màu sắc

CAÙC TÖØ VIEÁT TAÉT

|         |                     |          |                     |
|---------|---------------------|----------|---------------------|
| Ass'y   | Assembly            | MPH      | Miles per hour      |
| Comp.   | Complete            | L (100L) | Link (100 Links)    |
| R       | Right               | A.C      | Alternating Current |
| L       | Left                | D.C      | Direct Current      |
| STD     | Standard            | IN       | Inlet               |
| mm      | Millimeter          | EX       | Exhaust             |
| T (22T) | Tooth (22 Teeth)    | FR       | Front               |
| A       | Ampere              | RR       | Rear                |
| V       | Volt                | HEX      | Hexagonal           |
| W       | Watt                | A.M      | Attaching mark      |
| KPH     | Kilometers per hour | T.M      | Transcript mark     |

KÍCH THỜÙC

| Phụ tương    | Ví dụ   | Nhãn biết  |
|--------------|---------|--|
| Bulon (Vít)  | 6x12    | Ñòðong kính 6 mm, chieàu daøi 12 mm                              |
| Choát ñòngh  | 8x14    | Ñòðong kính 8 mm, chieàu daøi 14 mm                              |
| Voøng O-ring | 9.5x1.6 | Ñòðong kính 9.5 mm, beà daày 1.6 mm                              |
| Phoát daàu   | 14x24x5 | Ñòðong kính trong 14 mm, ñòðong kính ngoaøi 24 mm, beà daày 5 mm |
| OÁng daãn    | 5x130   | Ñòðong kính trong 5 mm, chieàu daøi 130                          |

**HOW TO USE THIS PARTS CATALOGUE**

MAKE UP OF THE PARTS NUMBER

- 1. Engine group
  - 2. Frame group
- Functional code of part number  
Example: General parts

00000 - 000 - 0000 - 00

Function and component number      Model code number      Manufacture code Modification designation

Example: Bolts, nuts and other standard parts

00000 - 00000 - 00

Function and component number      Dimension      Chemical surface treatment





ABBREVIATIONS

|         |                     |          |                     |
|---------|---------------------|----------|---------------------|
| Ass'y   | Assembly            | MPH      | Miles per hour      |
| Comp.   | Complete            | L (100L) | Link (100 Links)    |
| R       | Right               | A.C      | Alternating Current |
| L       | Left                | D.C      | Direct Current      |
| STD     | Standard            | IN       | Inlet               |
| mm      | Millimeter          | EX       | Exhaust             |
| T (22T) | Tooth (22 Teeth)    | FR       | Front               |
| A       | Ampere              | RR       | Rear                |
| V       | Volt                | HEX      | Hexagonal           |
| W       | Watt                | A.M      | Attaching mark      |
| KPH     | Kilometers per hour | T.M      | Transcript mark     |

DIMENSION



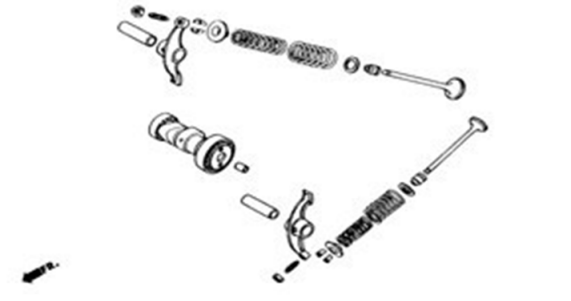
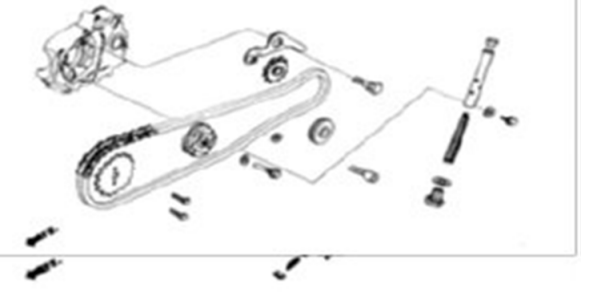
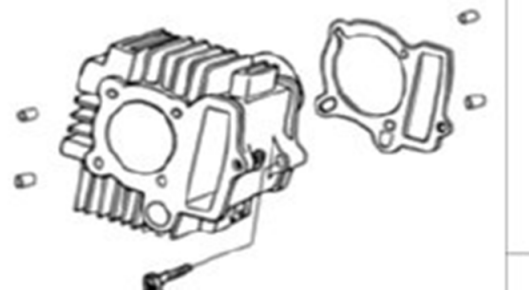
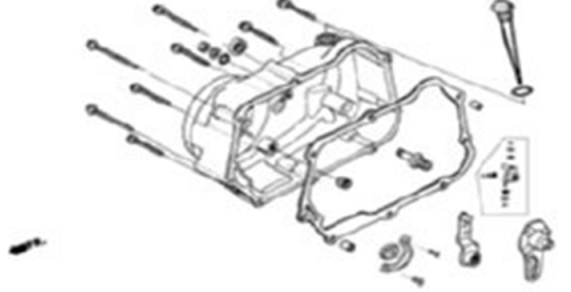

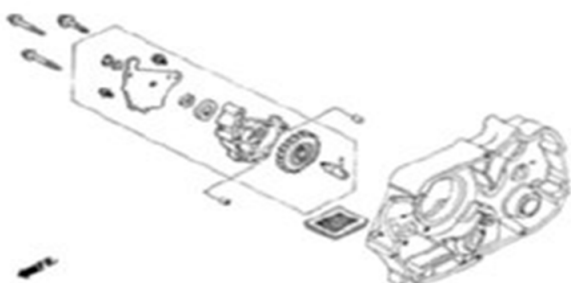

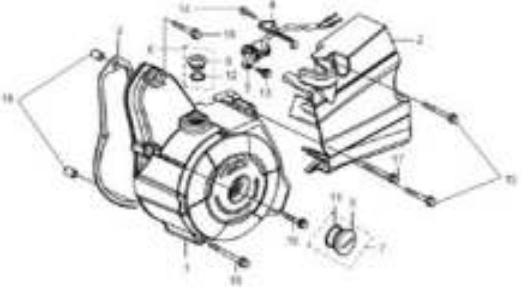

| Parts        | Example | Interpretation  |
|--------------|---------|---|
| Bolt (Screw) | 6x12    | 6 mm diameter, 12 mm length                                   |
| Pin          | 8x14    | 8 mm diameter, 14 mm length                                   |
| O-ring       | 9.5x1.6 | 9.5 mm diameter, 1.6 mm thickness                             |
| Oil seal     | 14x24x5 | 14 mm inside diameter, 24 mm outside diameter, 5 mm thickness |
| Tube         | 5x130   | 5 mm inside diameter, 130 mm length                           |

**CÁC BỘ PHẬN CỦA ĐỘNG CƠ**  
**CONTENTS - ENGINE GROUP**

|   |  |   |
|---|--|---|
| <p><b>E-01</b> Nắp đầu Xi Lanh<br/>Cylinder Head Cover P-7</p>                      | <p><b>E-02</b> Đầu Xi Lanh<br/>Cylinder Head P-8</p>                                 | <p><b>E-03</b> Trục Cam- Xu Pháp<br/>Cam Shaft - Valve P-9</p>                        |
|    |    |    |
| <p><b>E-04</b> Xích Cam - Căng Xích Cam<br/>Cam Chain - Tensioner P-10</p>          | <p><b>E-05</b> Xilanh<br/>Cylinder P-12</p>  | <p><b>E-06</b> Nắp Máy Bên Phải<br/>Right Crank Case Cover P-13</p>                   |
|   |   |   |
| <p><b>E-07</b> Bộ Ly Hợp Tâm<br/>Centrifugal Clutch Ass'Y P-15</p>                  | <p><b>E-08</b> Bộ Ly Hợp Ma Sát<br/>Clutch Outer Ass'Y P-17</p>                      | <p><b>E-09</b> Bộ Bơm Dầu<br/>Oil Pump Ass'Y P-18</p>                                 |
|  |  |  |

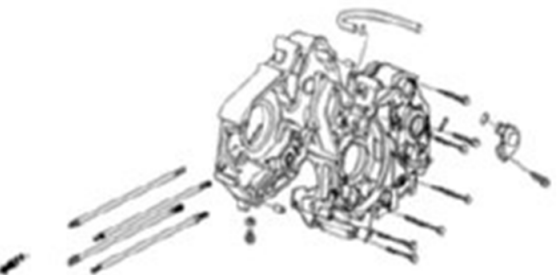
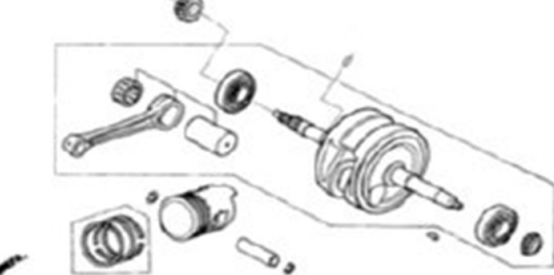
PRICE SHOWN IS PER PIECE. PRODUCT IMAGE PRICES ARE APPROXIMATE GUIDE ONLY.  
PRICES SHOWN ARE SUBJECT TO CHANGE WITHOUT PRIOR NOTICE.

**CÁC BỘ PHẬN CỦA ĐỘNG CƠ**  
**CONTENTS - ENGINE GROUP**

|   |  |   |
|---|--|---|
| <p><b>E-10</b>      Nắp máy bên trái<br/>Left Crank Case Cover      P-19</p>        | <p><b>E-11</b>      Bộ Phát Điện<br/>Generator      P-21</p>                         | <p><b>E-12</b>      Ly Hợp Khởi Động<br/>Starting Clutch      P-22</p>                |
|    |    |    |
| <p><b>E-13</b>      Mô-Tơ Khởi Động<br/>Starting Motor      P-23</p>                | <p><b>E-14</b>      Hộp Trục Khuỷu<br/>Crank Case      P-24</p>                      | <p><b>E-15</b>      Bộ Trục Khuỷu-Piston<br/>Crank Shaft-Piston      P-25</p>         |
|   |   |   |
| <p><b>E-16</b>      Bộ Số<br/>Transmission      P-27</p>                            | <p><b>E-17</b>      Trống Số<br/>Gear Shift      P-29</p>                            | <p><b>E-18</b>      Trục Khởi Động<br/>Kick Starter Spindle      P-31</p>             |
|  |  |  |





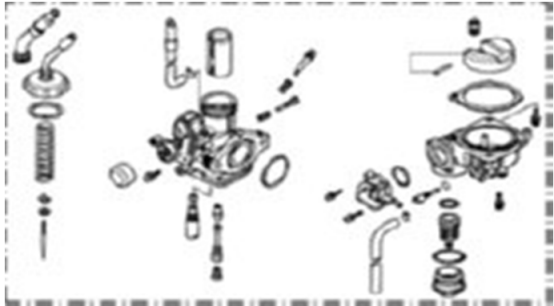

PRICE SHOWN IS PER PIECE. PRODUCT IMAGE PRICES ARE APPROXIMATE GUIDE ONLY.  
PRICES SHOWN ARE SUBJECT TO CHANGE WITHOUT PRIOR NOTICE.

**CÁC BỘ PHẬN CỦA ĐỘNG CƠ**  
**CONTENTS - ENGINE GROUP**

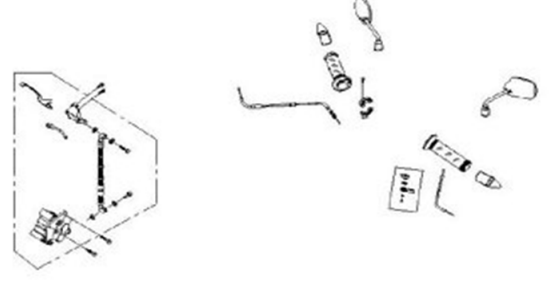
|   |                              |      |  |
|---|------------------------------|------|--|
| <b>E-19</b>   | Bộ Chế Hòa Khí<br>Carburetor | P-32 |  |
|  |                              |      |  |
|   |                              |      |  |
|   |                              |      |  |
|   |                              |      |  |
|   |                              |      |  |

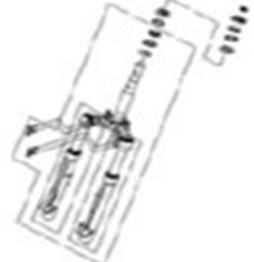
PRICE SHOWN IS PER PIECE. PRODUCT IMAGE PRICES ARE APPROXIMATE GUIDE ONLY.  
 PRICES SHOWN ARE SUBJECT TO CHANGE WITHOUT PRIOR NOTICE.

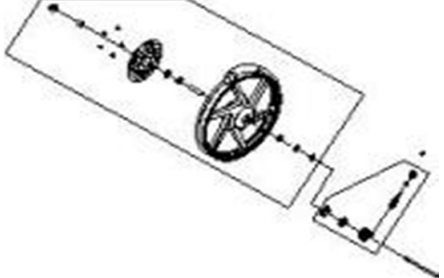

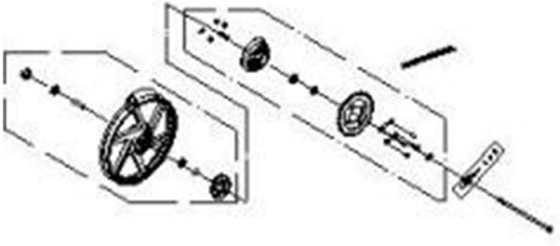

**CÁC BỘ PHẬN CỦA KHUNG SƯỜN**  
**CONTENTS - FRAME GROUP**

|   |  |   |
|---|--|---|
| <p><b>F-01</b> Đèn Trước<br/>Head Light P-33</p>                                    | <p><b>F-02</b> Thẳng Trước-Kính Chiếu Hậu<br/>Front Brake-Back Mirror P-34</p>       | <p><b>F-03</b> Nắp Tay Lái<br/>Handle Cover P-36</p>                                  |
|    |    |    |
| <p><b>F-04</b> Top Cover-Front Fender<br/>Mặt Nạ Trước-Vè Trước P-38</p>            | <p><b>F-05</b> Bộ Phuộc Trước<br/>Front Fork Set P-39</p>                            | <p><b>F-06</b> Bùng Trước- Yếm Bùng<br/>Front Cover-Main Pipe Cover P-40</p>          |
|   |   |   |
| <p><b>F-07</b> Front Wheel-Brake Disk<br/>Bánh Trước-Thắng Đĩa P-41</p>             | <p><b>F-08</b> Má Đùm Sau<br/>Rear Brake Panel P-43</p>                              | <p><b>F-09</b> Bánh Sau<br/>Rear Wheel P-45</p>                                       |
|  |  |  |

PRICE SHOWN IS PER PIECE. PRODUCT IMAGE PRICES ARE APPROXIMATE GUIDE ONLY.  
PRICES SHOWN ARE SUBJECT TO CHANGE WITHOUT PRIOR NOTICE.



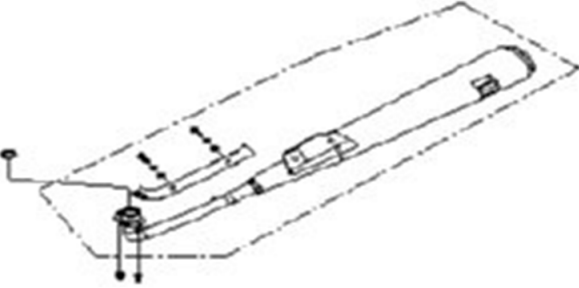
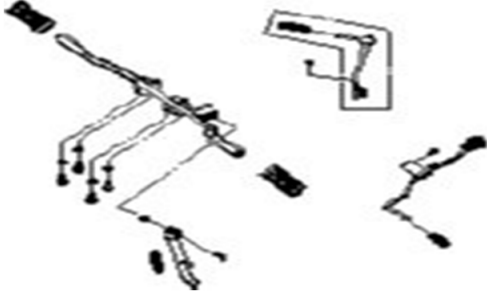

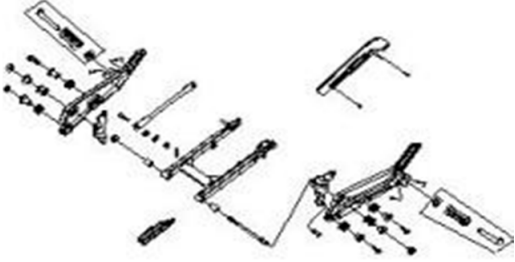
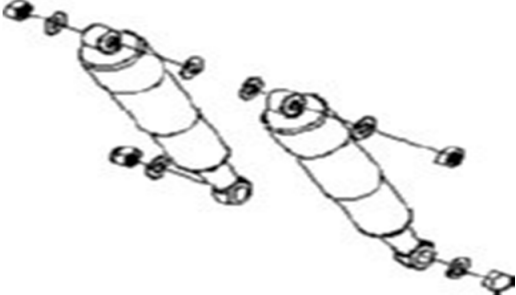
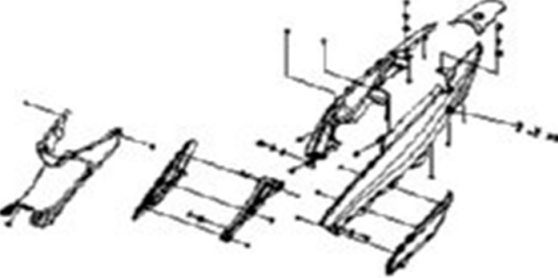

FRAME GROUP1

**CÁC BỘ PHẬN CỦA KHUNG SƯỜN**  
**CONTENTS - FRAME GROUP**

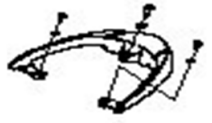
|   |  |   |
|---|--|---|
| <p><b>F-10</b> Yên Xe<br/>Double Seat P-47</p>                                      | <p><b>F-11</b> Thùng Xăng<br/>Fuel Tank P-48</p>                                     | <p><b>F-12</b> Bộ Lọc Gió<br/>Air Cleaner P-49</p>                                    |
|    |    |    |
| <p><b>F-13</b> Ống Xả<br/>Exhaust Muffler P-50</p>                                  | <p><b>F-14</b> Cần Đỡ Chân-Cần Đạp Khởi Động<br/>Step Bar-Kick Starter Arm P-51</p>  | <p><b>F-15</b> Chống Đứng-Bàn Đạp Thắng<br/>Main Stand-Brake Pedal P-52</p>           |
|   |   |   |
| <p><b>F-16</b> Gấp Sau-Hộp Xích Tải<br/>Rear Fork - Chain Case P-53</p>             | <p><b>F-17</b> Bộ Phuộc Sau<br/>Rear Cushion P-55</p>                                | <p><b>F-18</b> Ôp Sườn<br/>Body Cover P-56</p>  |
|  |  |  |

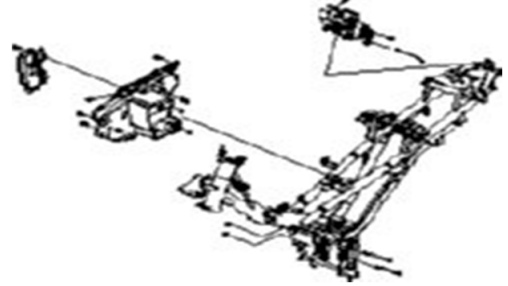
PRICE SHOWN IS PER PIECE. PRODUCT IMAGE PRICES ARE APPROXIMATE GUIDE ONLY.  
PRICES SHOWN ARE SUBJECT TO CHANGE WITHOUT PRIOR NOTICE.

**CÁC BỘ PHẬN CỦA KHUNG SƯỜN**  
**CONTENTS - FRAME GROUP**

|   |   |  |
|---|---|--|
| <p><b>F-19</b>      Vè Sau-Đèn Sau<br/>Rear Fender-Tail Light      P-58</p>         | <p><b>F-20</b>      Tay Nắm<br/>Rear Carrier      P-60</p>                          | <p><b>F-21</b>      Dây Điện - Bình Điện<br/>Wire Harness - Battery      P-61</p>    |
|    |   |   |
| <p><b>F-22</b>      Khung Xe<br/>Frame Body      P-62</p>                           | <p><b>F-23</b>      Tem Chỉ Dẫn<br/>Caution Mark      P-63</p>                      | <p><b>F-24</b>      Đề Can Xe<br/>Stripe      P-64</p>                               |
|   |  |  |
| <p><b>F-25</b>      Bộ Dụng Cụ<br/>Tool Ass'Y      P-65</p>                         |   |  |
|  |   |  |

PRICE SHOWN IS PER PIECE. PRODUCT IMAGE PRICES ARE APPROXIMATE GUIDE ONLY.  
 PRICES SHOWN ARE SUBJECT TO CHANGE WITHOUT PRIOR NOTICE.

E01

**CYLINDER HEAD COVER**  
**NÁP ĐẦU XI-LANH**

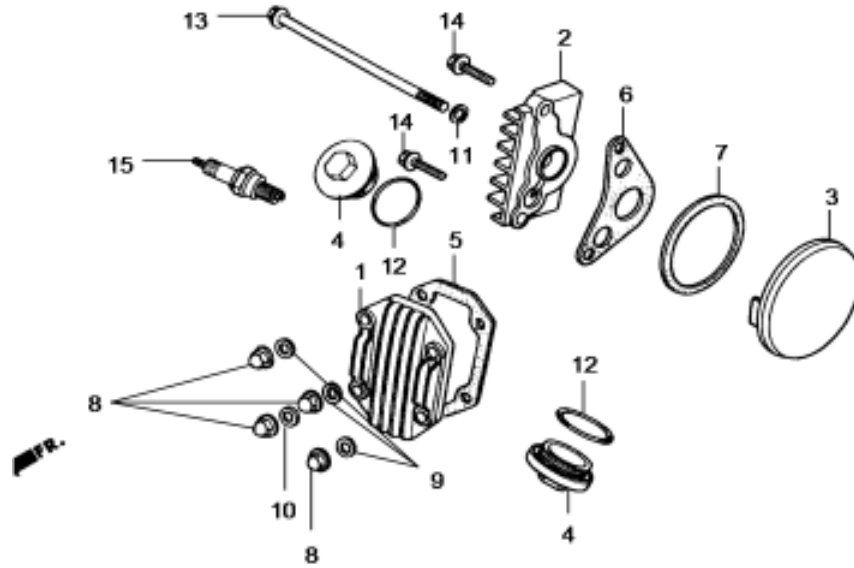

| STT No. | VMEP CODE      | SELLING PRICE RM/PCS | Tên phụ tùng<br>Description   | S.lượng<br>Unit | STT No. | Mã E/C. | Ghi chú<br>Remark |
|---------|----------------|----------------------|-------------------------------|-----------------|---------|---------|-------------------|
| 1       | 12301-A01-A000 | 11.20                | Cylinder Head Cover           | 1               |         |         |                   |
| 2       | 12331-A01-A000 | 11.20                | R. Cylinder Head Side Cover   | 1               |         |         |                   |
| 3       | 12341-A04-A000 | 11.20                | L. Cylinder Head Side Cover   | 1               |         |         |                   |
| 4       | 12361-M9Q-0000 | 8.20                 | Tappet Adjusting Hold Cap     | 2               |         |         |                   |
| 5       | 12391-VN7-0000 | 2.60                 | Cylinder Head Cover Gasket    | 1               |         |         |                   |
| 6       | 12394-VN7-0000 | 0.70                 | R. Cylinder Head Cover Gasket | 1               |         |         |                   |
| 7       | 12395-VN7-0000 | 1.00                 | L. Cylinder Head Cover Gasket | 1               |         |         |                   |
| 8       | 90201-VA2-0002 | 1.10                 | Cap Nut 7 mm                  | 4               |         |         |                   |
| 9       | 90442-VA2-0000 | 0.70                 | Sealing Washer 7 mm           | 3               |         |         |                   |
| 10      | 90443-VA2-0000 | 0.70                 | Sealing Washer A 7 mm         | 1               |         |         |                   |
| 11      | 90461-VA2-0001 | 0.70                 | Sealing Washer 6.5x12         | 1               |         |         |                   |
| 12      | 91302-M9Q-0000 | 0.60                 | O-Ring 30.8x3.2               | 2               |         |         |                   |
| 13      | 95701-06110-00 | 1.20                 | Flange Bolt 6x110             | 1               |         |         |                   |
| 14      | 96001-06025-00 | 0.70                 | Sh. Flange Bolt 6x25          | 2               |         |         |                   |
| 15      | AC-1201-0001   | 8.30                 | Spark Plug C6HSA (NGK)        | 1               |         |         |                   |

PRICE SHOWN IS PER PIECE. PRODUCT IMAGE PRICES ARE APPROXIMATE GUIDE ONLY.  
PRICES SHOWN ARE SUBJECT TO CHANGE WITHOUT PRIOR NOTICE.

E01



## CYLINDER HEAD

**E02**

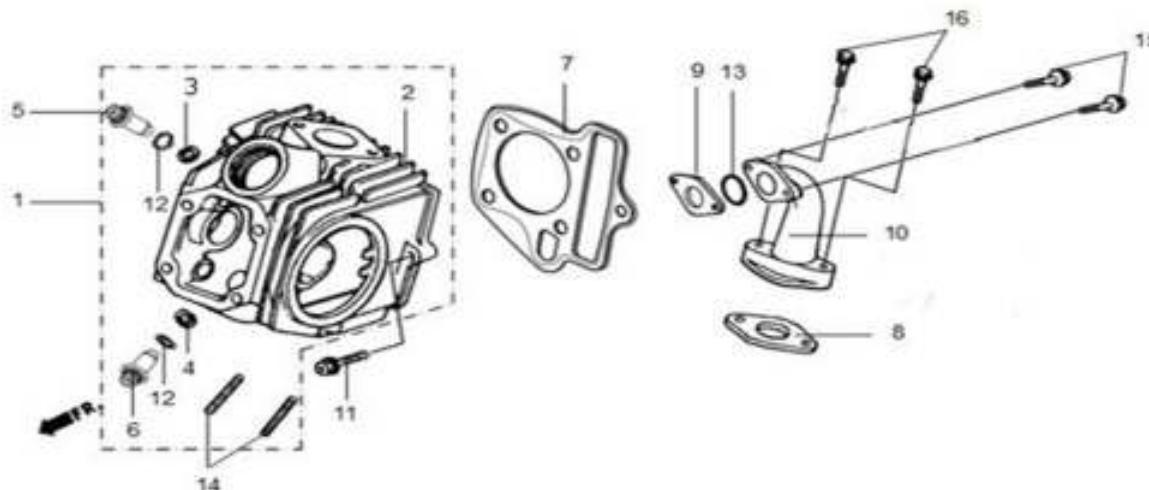

| STT No. | VMEP CODE         | SELLING PRICE RM/PCS | Tên phụ tùng<br>Description | S.lượng<br>Unit | STT No. | Mã E/C. | Ghi chú<br>Remark |
|---------|-------------------|----------------------|-----------------------------|-----------------|---------|---------|-------------------|
| 1       | 1220A-A04-A002    | 312.70               | Cylinder Head Ass'y         | 1               |         |         |                   |
| 2       | 12200-SA5-0001-VN | 281.40               | Cylinder Head Comp.         | 1               |         |         |                   |
| 3       | 12225-VA2-3002    | 13.70                | Inlet Valve Seat            | 1               |         |         |                   |
| 4       | 12226-VA2-3002    | 13.70                | Exhaust Valve Seat          | 1               |         |         |                   |
| 5       | 12237-GB4-6812    | 9.80                 | Inlet Valve Guide           | 1               |         |         |                   |
| 6       | 12245-GB4-6812    | 9.80                 | Exhaust Valve Guide         | 1               |         |         |                   |
| 7       | 12251-VA2-0001    | 9.90                 | Cylinder Head Gasket        | 1               |         |         |                   |
| 8       | 16201-VN7-0000    | 0.70                 | Carburator Insulator Gasket | 1               |         |         |                   |
| 9       | 16211-A01-A000    | 2.20                 | Carburetor Insulator        | 1               |         |         |                   |
| 10      | 17110-SM1-0000-VN | 22.20                | Inlet Pipe                  | 1               |         |         |                   |
| 11      | 90081-VA2-0000    | 1.90                 | Special Flange Bolt 6x23    | 1               |         |         |                   |
| 12      | 91305-028-1583    | 1.00                 | O-Ring 9x1.6 mm             | 2               |         |         |                   |
| 13      | 91308-M9Q-0000    | 1.60                 | O-Ring 25x2.4 mm            | 1               |         |         |                   |
| 14      | 92700-A02-0001    | 1.00                 | Stud Bolt 6x32 mm           | 2               |         |         |                   |
| 15      | 96001-06025-00    | 0.70                 | Sh. Flange Bolt 6x25        | 2               |         |         |                   |
| 16      | 96001-06028-07    | 0.70                 | Sh. Flange Bolt 6x28        | 2               |         |         |                   |

PRICE SHOWN IS PER PIECE. PRODUCT IMAGE PRICES ARE APPROXIMATE GUIDE ONLY.  
PRICES SHOWN ARE SUBJECT TO CHANDE WITHOUT PRIOR NOTICE.

E03

## CAM SHAFT - VALVE

TRỤC CAM - XU PÁP

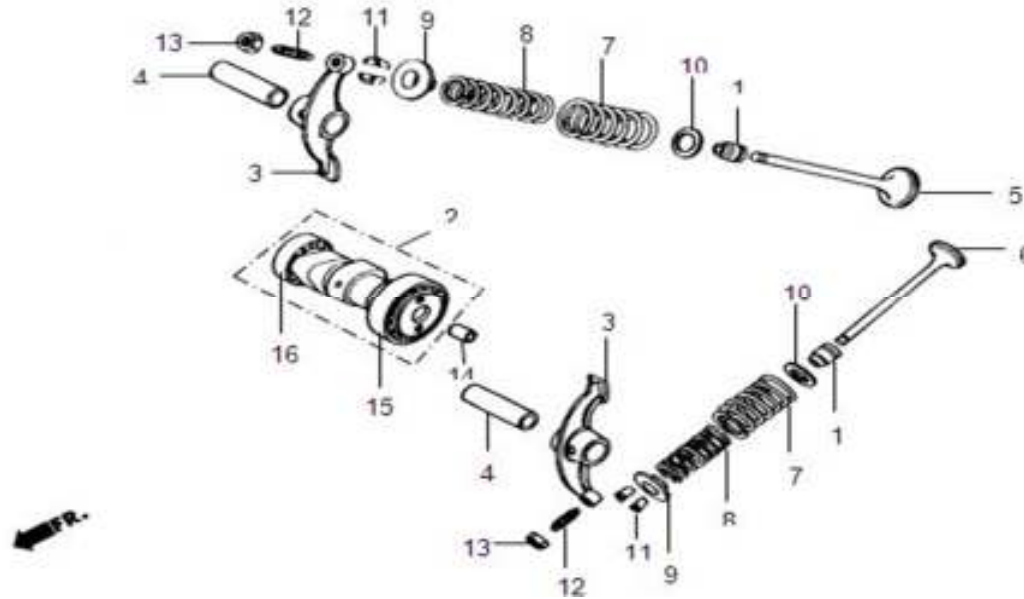

| STT No. | VMEP CODE         | SELLING PRICE RM/PCS | Tên phụ tùng<br>Description | S.lượng<br>Unit | STT No. | Mã E/C. | Ghi chú<br>Remark |
|---------|-------------------|----------------------|-----------------------------|-----------------|---------|---------|-------------------|
| 1       | 12209-H6B-0000    | 6.70                 | Valve Stem Seal             | 2               |         |         |                   |
| 2       | 14100-VA2-0003    | 125.80               | Cam Shaft Comp.             | 1               |         |         |                   |
| 3       | 14431-M8Q-0000    | 46.90                | Valve Rocker Arm            | 2               |         |         |                   |
| 4       | 14451-M8Q-0000    | 7.00                 | Rocker Arm Shaft            | 2               |         |         |                   |
| 5       | 14711-VA2-0001    | 14.40                | Inlet Valve                 | 1               |         |         |                   |
| 6       | 14721-VA2-0001    | 26.70                | Exhaust Valve               | 1               |         |         |                   |
| 7       | 14751-M8Q-0000    | 6.20                 | Valve Outer Spring          | 2               |         |         |                   |
| 8       | 14761-M8Q-0000    | 5.40                 | Valve Inner Spring          | 2               |         |         |                   |
| 9       | 14771-A01-A000    | 5.40                 | Valve Spring Retainer       | 2               |         |         |                   |
| 10      | 14775-M9Q-0000    | 0.80                 | Valve Spring Outer Seat     | 2               |         |         |                   |
| 11      | 14781-A01-A000    | 2.40                 | Valve Cotter                | 4               |         |         |                   |
| 12      | 90012-M9Q-0000    | 2.20                 | Tappet Adjusting Screw      | 2               |         |         |                   |
| 13      | 90206-001-0007    | 1.60                 | Tappet Adjusting Screw Nut  | 2               |         |         |                   |
| 14      | 90702-M8Q-0000    | 1.00                 | Dowel Pin 8x12              | 1               |         |         |                   |
| 15      | 96100-69050-00    | 13.50                | Radail Ball Brg. 6905       | 1               |         |         |                   |
| 16      | 96120-69020-10    | 11.20                | Radail Ball Brg. 6902Z      | 1               |         |         |                   |
| 17      | 14150-VAH-0001-VN | 3.60                 | Stopper Plate Comp.         | 1               |         |         |                   |

PRICE SHOWN IS PER PIECE. PRODUCT IMAGE PRICES ARE APPROXIMATE GUIDE ONLY.  
PRICES SHOWN ARE SUBJECT TO CHANDE WITHOUT PRIOR NOTICE.

E03

E04

## CAM CHAIN - TENSIONER

XÍCH CAM - CĂNG XÍCH CAM

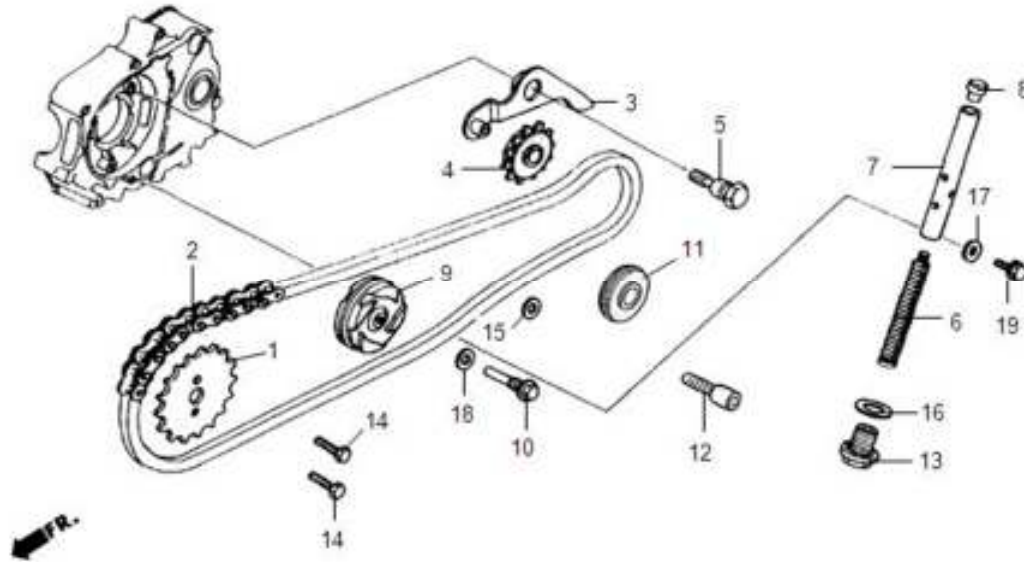

| STT No. | VMEP CODE         | SELLING PRICE RM/PCS | Tên phụ tùng<br>Description      | S.lượng<br>Unit | STT No. | Mã E/C. | Ghi chú<br>Remark |
|---------|-------------------|----------------------|----------------------------------|-----------------|---------|---------|-------------------|
| 1       | 14321-VA2-0001    | 9.30                 | Cam Sprocket (32T)               | 1               |         |         |                   |
| 2       | 1CK 25H X 90L     | 14.10                | Cam Chain (90L)                  | 1               |         |         |                   |
| 3       | 14500-A01-A001-L1 | 7.80                 | Cam Chain Tensioner Arm Comp.    | 1               |         |         |                   |
| 4       | 14502-M8Q-0000    | 7.80                 | Cam Chain Tensioner Roller       | 1               |         |         |                   |
| 5       | 14531-A08-0000    | 3.60                 | Cam Chain Tensioner Pivot        | 1               |         |         |                   |
| 6       | 14541-M8Q-0100    | 0.80                 | Cam Chain Tensioner Spring       | 1               |         |         |                   |
| 7       | 14550-M8Q-0000    | 14.40                | Tensioner Push Rod Comp.         | 1               |         |         |                   |
| 8       | 14566-A08-0101    | 1.10                 | Tensioner Push Rod Head          | 1               |         |         |                   |
| 9       | 14610-VA2-0001    | 10.20                | Cam Chain Guide Roller Comp. (B) | 1               |         |         |                   |
| 10      | 14615-VA2-0000    | 1.80                 | Roller Guide Pin                 | 1               |         |         |                   |
| 11      | 14670-VA2-0001    | 12.30                | Chain Guide Roller Comp. (A)     | 1               |         |         |                   |
| 12      | 14675-VA2-0000    | 1.20                 | Cam Chain Guide Roller Bolt      | 1               |         |         |                   |
| 13      | 90081-035-0006    | 1.90                 | Sealing Bolt 14 mm               | 1               |         |         |                   |
| 14      | 90083-A08-0000    | 0.70                 | Knock Bolt 5 mm                  | 2               |         |         |                   |
| 15      | 90405-VA2-0000    | 0.70                 | Plain Washer 6.5x16x2.6          | 1               |         |         |                   |
| 16      | 90441-M8Q-0000    | 0.70                 | Seal Washer 14 mm                | 1               |         |         |                   |

PRICE SHOWN IS PER PIECE. PRODUCT IMAGE PRICES ARE APPROXIMATE GUIDE ONLY.  
PRICES SHOWN ARE SUBJECT TO CHANGE WITHOUT PRIOR NOTICE.

E04

**CAM CHAIN - TENSIONER**  
**XÍCH CAM - CĂNG XÍCH CAM**

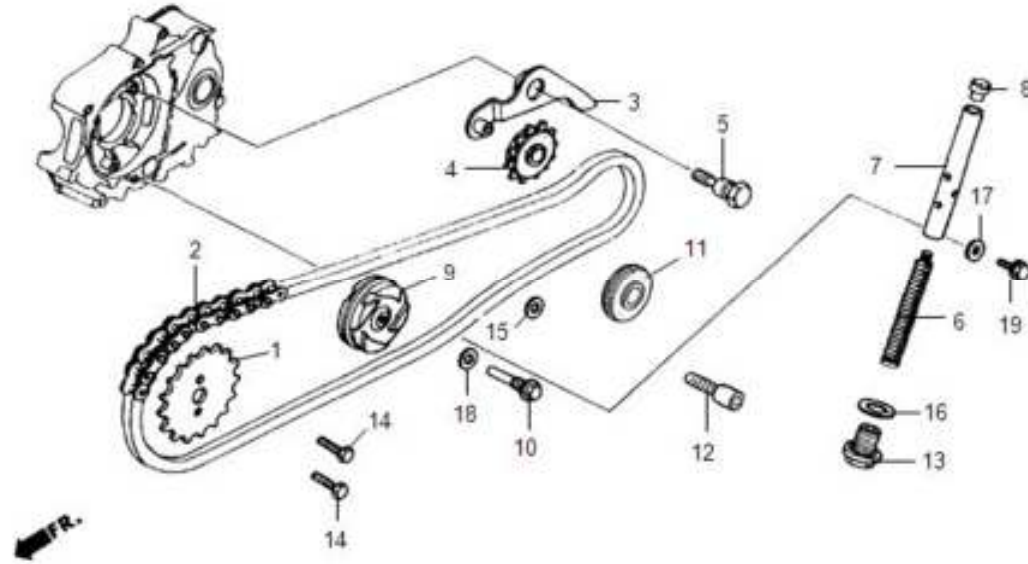

| STT No. | VMEP CODE      | SELLING PRICE RM/PCS | Tên phụ tùng<br>Description | S.lượng<br>Unit | STT No. | Mã E/C. | Ghi chú<br>Remark |
|---------|----------------|----------------------|-----------------------------|-----------------|---------|---------|-------------------|
| 17      | 90461-VA2-0001 | 0.70                 | Sealing Washer 6.5x12 mm    | 1               |         |         |                   |
| 18      | 90481-035-0001 | 0.70                 | Washer 8 mm                 | 1               |         |         |                   |
| 19      | 95701-06018-07 | 0.40                 | Flange Bolt 6x18            | 1               |         |         |                   |
|         |                |                      |                             |                 |         |         |                   |
|         |                |                      |                             |                 |         |         |                   |
|         |                |                      |                             |                 |         |         |                   |
|         |                |                      |                             |                 |         |         |                   |
|         |                |                      |                             |                 |         |         |                   |
|         |                |                      |                             |                 |         |         |                   |
|         |                |                      |                             |                 |         |         |                   |
|         |                |                      |                             |                 |         |         |                   |
|         |                |                      |                             |                 |         |         |                   |
|         |                |                      |                             |                 |         |         |                   |
|         |                |                      |                             |                 |         |         |                   |
|         |                |                      |                             |                 |         |         |                   |
|         |                |                      |                             |                 |         |         |                   |
|         |                |                      |                             |                 |         |         |                   |
|         |                |                      |                             |                 |         |         |                   |
|         |                |                      |                             |                 |         |         |                   |

PRICE SHOWN IS PER PIECE. PRODUCT IMAGE PRICES ARE APPROXIMATE GUIDE ONLY.  
 PRICES SHOWN ARE SUBJECT TO CHANDE WITHOUT PRIOR NOTICE.

E05

**CYLINDER  
XI-LANH**

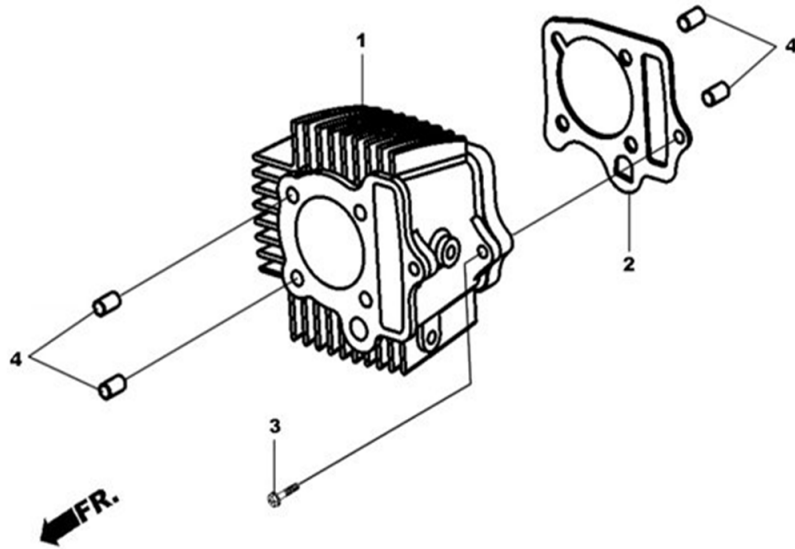

| STT No. | VMEP CODE      | SELLING PRICE RM/PCS | Tên phụ tùng Description | S.lượng Unit | STT No. | Mã E/C. | Ghi chú Remark |
|---------|----------------|----------------------|--------------------------|--------------|---------|---------|----------------|
| 1       | 12101-A04-A000 | 146.60               | Cylinder                 | 1            |         |         |                |
| 2       | 12191-VN7-0000 | 2.20                 | Cylinder Gasket          | 1            |         |         |                |
| 3       | 90081-VA2-0000 | 1.90                 | Special Flange Bolt 6x23 | 1            |         |         |                |
| 4       | 90702-VA2-000  | 1.40                 | Dowel Pin 8x14           | 4            |         |         |                |
|         |                |                      |                          |              |         |         |                |
|         |                |                      |                          |              |         |         |                |
|         |                |                      |                          |              |         |         |                |
|         |                |                      |                          |              |         |         |                |
|         |                |                      |                          |              |         |         |                |
|         |                |                      |                          |              |         |         |                |
|         |                |                      |                          |              |         |         |                |
|         |                |                      |                          |              |         |         |                |

PRICE SHOWN IS PER PIECE. PRODUCT IMAGE PRICES ARE APPROXIMATE GUIDE ONLY.  
PRICES SHOWN ARE SUBJECT TO CHANDE WITHOUT PRIOR NOTICE.

E06

RIGHT CRANK CASE COVER

NÁP MÁY BÊN PHẢI

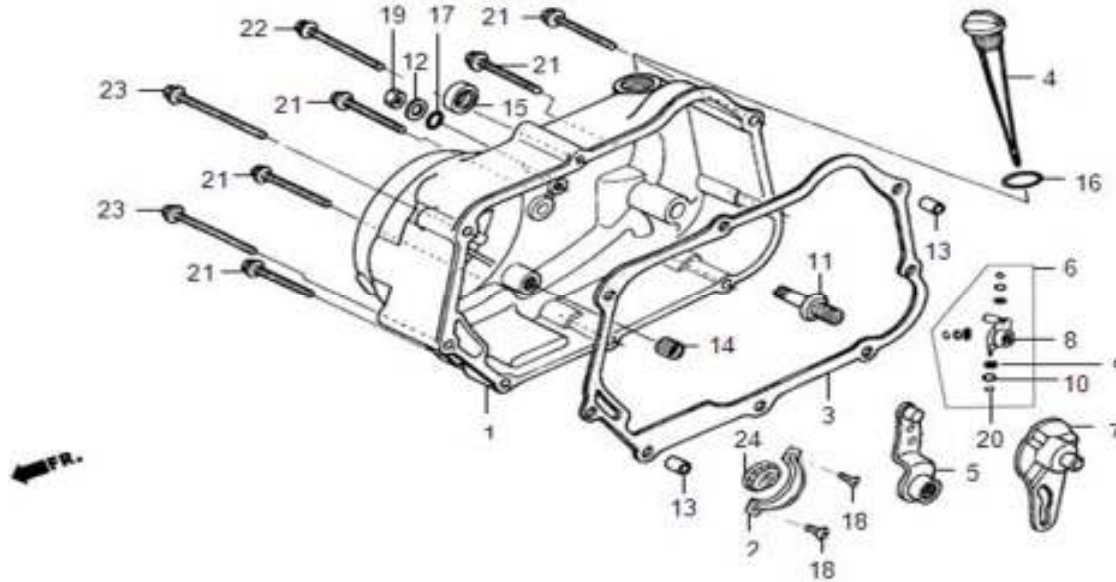

| STT No. | VMEP CODE         | SELLING PRICE RM/PCS | Tên phụ tùng<br>Description | S.lượng<br>Unit | STT No. | Mã E/C. | Ghi chú<br>Remark                                   |
|---------|-------------------|----------------------|-----------------------------|-----------------|---------|---------|---|
| 1       | 11330-VA2-0011-IC | 109.40               | R. Crank Case Cover Comp.   | 1               |         |         |   |
| 2       | 11338-M3G-0003    | 2.00                 | Bearing Retainer A          | 1               |         |         |   |
| 3       | 11394-VN7-0000    | 3.90                 | R. Crank Case Cover Gasket  | 1               |         |         |   |
| 4       | 1565A-VA1-0000    | 4.40                 | Oil Level Gauge             | 1               |         |         |   |
| 5       | 22810-VA2-0000    | 16.80                | Clutch Lever Comp.          | 1               |         |         |   |
| 6       | 22820-M3G-0001    | 30.00                | Clutch Lifter Boss Ass'y    | 1               |         |         | PARENT PART   |
| 7       | 22820-A01-A000    | 4.70                 | Clutch Lifter Plate Comp.   | 1               |         |         |   |
| 8       | 22821-M3G-0001    | 18.70                | Clutch Lifter Boss          | 1               |         |         |   |
| 9       | 22822-M3G-0000(X) |                      | Clutch Lifter Boss Roller   | 3               |         |         | CHILD PART, PLEASE ORDER PARENT PART 22820-M3G-0001 |
| 10      | 22823-M3G-0000(X) |                      | Clutch Lifter Boss Washer   | 3               |         |         |   |
| 11      | 22864-VA2-0000    | 6.70                 | Clutch Adjusting Bolt       | 1               |         |         |   |
| 12      | 90485-A08-0001    | 0.70                 | Washer 8 mm                 | 1               |         |         |   |
| 13      | 90702-VA2-000     | 1.40                 | Dowel Pin 8x12              | 2               |         |         |   |
| 14      | 91021-148-0040    | 11.20                | Needle Bearing HK 1010      | 1               |         |         |   |
| 15      | 91202-VA2-0000    | 2.20                 | Oil Seal 13.7x24x5          | 1               |         |         |   |
| 16      | 91307-B06-0000    | 1.60                 | O-Ring 18x3 mm              | 1               |         |         |   |

PRICE SHOWN IS PER PIECE. PRODUCT IMAGE PRICES ARE APPROXIMATE GUIDE ONLY.  
 PRICES SHOWN ARE SUBJECT TO CHANGE WITHOUT PRIOR NOTICE.

E06

**RIGHT CRANK CASE COVER**  
**NÁP MÁY BÊN PHẢI**

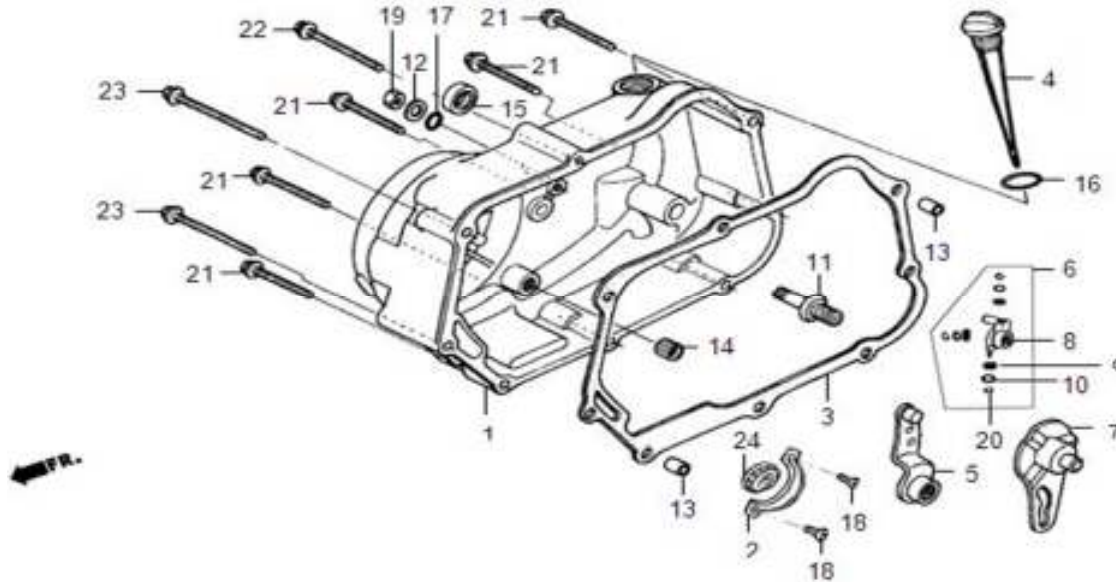

| STT No. | VMEP CODE      | SELLING PRICE RM/PCS | Tên phụ tùng<br>Description      | S.lượng<br>Unit | STT No. | Mã E/C. | Ghi chú<br>Remark                       |
|---------|----------------|----------------------|----------------------------------|-----------------|---------|---------|---|
| 17      | 91312-A01-A001 | 0.40                 | O-Ring 7.8 mm                    | 1               |         |         |   |
| 18      | 93600-06010-0A | 0.70                 | Flat Screw 6x10                  | 2               |         |         |   |
| 19      | 94030-08000-00 | 1.10                 | Hex Nut 8 mm                     | 1               |         |         |   |
| 20      | 94504-03018(X) |                      | E-Ring 3 mm                      | 3               |         |         | please order parent part 22820-M3G-0001 |
| 21      | 96001-06040-00 | 0.80                 | Sh. Flange Bolt 6x40             | 5               |         |         |   |
| 22      | 96001-06065-00 | 1.80                 | Sh. Flange Bolt 6x65             | 1               |         |         |   |
| 23      | 96001-06080-00 | 1.90                 | Sh. Flange Bolt 6x80             | 2               |         |         |   |
| 24      | 96140-60010-00 | 8.00                 | Radial Ball Bearing 6001LU (TPI) | 1               |         |         |   |
|         |                |                      |                                  |                 |         |         |   |
|         |                |                      |                                  |                 |         |         |   |
|         |                |                      |                                  |                 |         |         |   |
|         |                |                      |                                  |                 |         |         |   |

PRICE SHOWN IS PER PIECE. PRODUCT IMAGE PRICES ARE APPROXIMATE GUIDE ONLY.  
PRICES SHOWN ARE SUBJECT TO CHANGE WITHOUT PRIOR NOTICE.

E07

**CENTRIFUGAL CLUTCH ASS'Y**  
**BỘ LY HỢP LY TÂM**

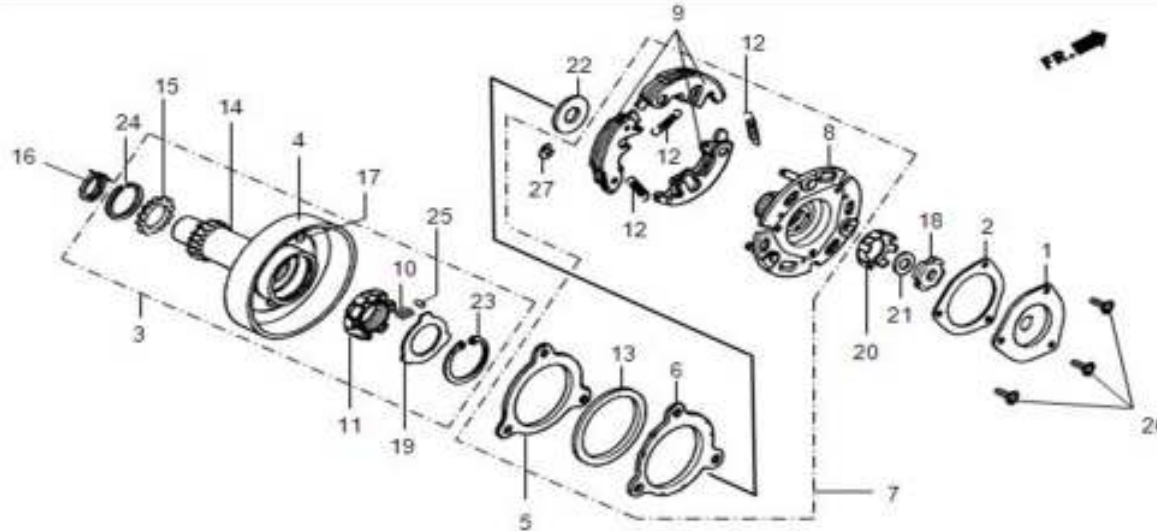

| STT No. | VMEP CODE         | SELLING PRICE RM/PCS | Tên phụ tùng<br>Description  | S.lượng<br>Unit | STT No. | Mã E/C. | Ghi chú<br>Remark                       |
|---------|-------------------|----------------------|------------------------------|-----------------|---------|---------|---|
| 1       | 15436-M3G-0100    | 7.20                 | Oil Filer Cover              | 1               |         |         |   |
| 2       | 15439-VA2-0000    | 1.20                 | Oil Filter Cover Gasket      | 1               |         |         |   |
| 3       | 2210B-A05-0001-VN | 74.90                | Centrifugal Clutch Outer Set | 1               |         |         |   |
| 4       | 22101-A05-3001(X) |                      | Centrifugal Clutch Outer     | 1               |         |         | please order parent part 22100-A05-0000 |
| 5       | 22111-M3G-0100    | 11.20                | Centrifugal Clutch Plate A   | 1               |         |         |   |
| 6       | 22112-M3G-0100    | 11.20                | Centrifugal Clutch Plate B   | 1               |         |         |   |
| 7       | 22300-A05-0000-VN | 112.30               | Clutch Drive Plate Ass'y     | 1               |         |         |   |
| 8       | 22350-M3G-0101    | 29.70                | Clutch Drive Plate Comp.     | 1               |         |         |   |
| 9       | 22530-M3G-0101    | 34.00                | Clutch Weight                | 3               |         |         |   |
| 10      | 22606-M3G-0000    | 0.70                 | One Way Retainer Spring      | 6               |         |         |   |
| 11      | 22630-M3G-0001    | 26.10                | One Way Clutch Inner Comp.   | 1               |         |         |   |
| 12      | 22641-M3G-0100    | 2.20                 | Clutch Spring B              | 3               |         |         |   |
| 13      | 23117-M3G-0100    | 5.50                 | Spring Plate                 | 1               |         |         |   |
| 14      | 23120-A05-0000(X) |                      | Primary Drive Gear           | 1               |         |         | please order parent part 22100-A05-0000 |
| 15      | 23122-A05-0000(X) |                      | Sub Gear                     | 1               |         |         | please order parent part 22100-A05-0000 |
| 16      | 23124-VA2-0001    | 3.70                 | Sub Gear Spring              | 1               |         |         |   |

PRICE SHOWN IS PER PIECE. PRODUCT IMAGE PRICES ARE APPROXIMATE GUIDE ONLY.  
 PRICES SHOWN ARE SUBJECT TO CHANDE WITHOUT PRIOR NOTICE.



E07

**CENTRIFUGAL CLUTCH ASS'Y**  
**BỘ LY HỢP LY TÂM**

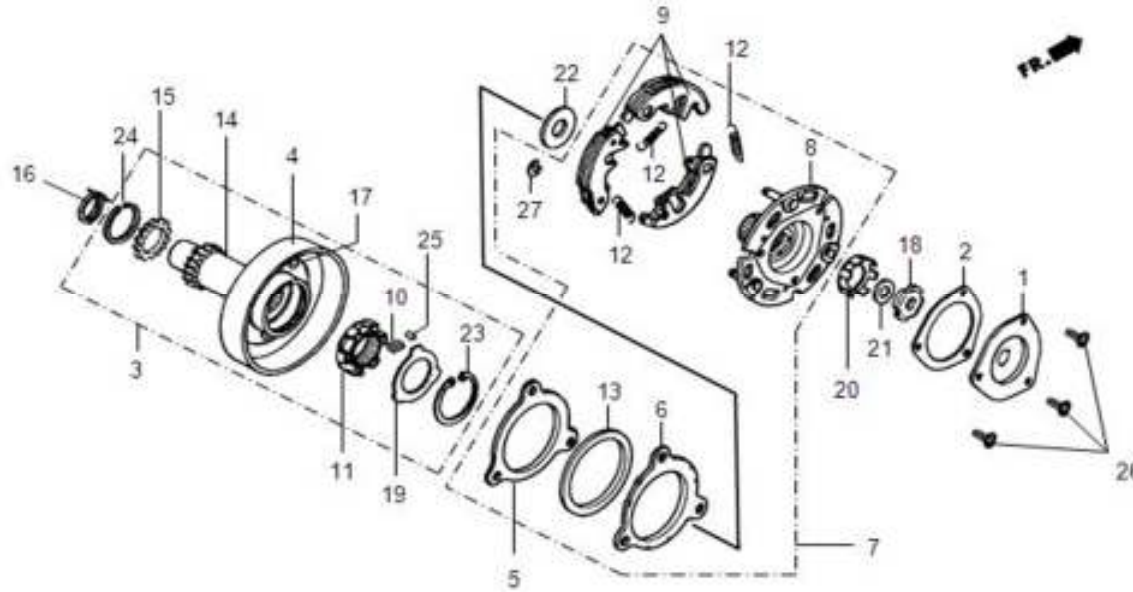

| STT No. | VMEP CODE         | SELLING PRICE RM/PCS | Tên phụ tùng<br>Description | S.lượng<br>Unit | STT No. | Mã E/C. | Ghi chú<br>Remark                       |
|---------|-------------------|----------------------|-----------------------------|-----------------|---------|---------|---|
| 17      | 23126-A05-3000(X) |                      | Rivet 5 mm                  | 3               |         |         | please order parent part 22100-A05-0000 |
| 18      | 90231-M8Q-0000    | 1.90                 | Lock Nut 14 mm              | 1               |         |         |   |
| 19      | 90401-M3G-0000    | 0.60                 | Washer 30x45x0.8            | 1               |         |         |   |
| 20      | 90431-M3G-0001    | 1.10                 | Lock Washer 14 mm           | 1               |         |         |   |
| 21      | 90432-SB1-0000    | 1.10                 | Lock Washer B 14 mm         | 1               |         |         |   |
| 22      | 90434-M3G-0000    | 0.70                 | Washer 17x23x3              | 1               |         |         |   |
| 23      | 90455-M3G-0000    | 1.60                 | Cir-Clip In 45 mm           | 1               |         |         |   |
| 24      | 90603-A05-0000(X) |                      | Set Ring 23 mm              | 1               |         |         | please order parent part 22100-A05-0000 |
| 25      | 91101-M3G-0000    | 1.60                 | Roller 5x8                  | 6               |         |         |   |
| 26      | 93500-05008-OA    | 0.40                 | Pan Screw 5x8               | 3               |         |         |   |
| 27      | 94540-07010       | 1.30                 | E-Ring 7 mm                 | 3               |         |         |   |
|         |                   |                      |                             |                 |         |         |   |
|         |                   |                      |                             |                 |         |         |   |
|         |                   |                      |                             |                 |         |         |   |

PRICE SHOWN IS PER PIECE. PRODUCT IMAGE PRICES ARE APPROXIMATE GUIDE ONLY.  
 PRICES SHOWN ARE SUBJECT TO CHANGE WITHOUT PRIOR NOTICE.

E08

**CLUTCH OUTER ASS'Y**  
**BỘ LY HỢP MA SẮT**

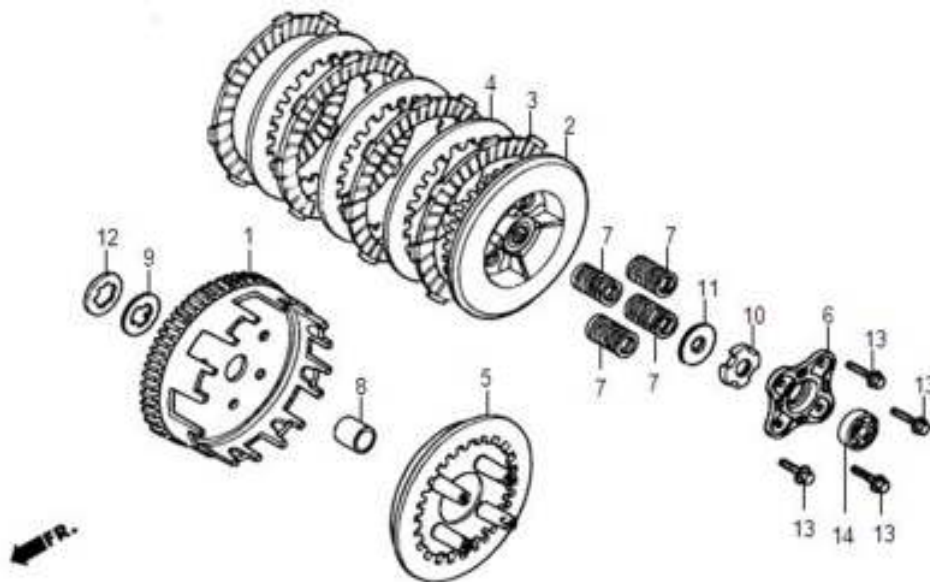

| STT No. | VMEP CODE         | SELLING PRICE RM/PCS | Tên phụ tùng<br>Description    | S.lượng<br>Unit | STT No. | Mã E/C. | Ghi chú<br>Remark |
|---------|-------------------|----------------------|--------------------------------|-----------------|---------|---------|-------------------|
| 1       | 2200A-A05-0004-VN | 180.90               | Clutch Outer Set               | 1               |         |         |                   |
| 2       | 22121-A05-0000    | 12.00                | Clutch Center                  | 1               |         |         |                   |
| 3       | 22201-107-0000-A  | 4.10                 | Clutch Friction Disk           | 4               |         |         |                   |
| 4       | 22311-107-0002    | 8.60                 | Clutch Plate                   | 3               |         |         |                   |
| 5       | 22351-A05-0000    | 30.00                | Clutch Pressure Plate          | 1               |         |         |                   |
| 6       | 22361-A05-0002    | 6.40                 | Clutch Lifter Plate            | 1               |         |         |                   |
| 7       | 22401-M3G-0001    | 2.00                 | Clutch Spring A                | 4               |         |         |                   |
| 8       | 22100-A05-0000    | 74.90                | Clutch Center Guide            | 1               |         |         |                   |
| 9       | 23217-M3G-0002    | 0.70                 | Set Ring 17 mm                 | 1               |         |         |                   |
| 10      | 90231-VA2-0000    | 1.90                 | Lock Nut 14 mm                 | 1               |         |         |                   |
| 11      | 90432-SB1-0000    | 1.10                 | Lock Washer B 14 mm            | 1               |         |         |                   |
| 12      | 90464-VA2-0000    | 0.70                 | Spline Washer 17 mm            | 1               |         |         |                   |
| 13      | 95701-06022-08    | 0.70                 | Flange Bolt 6x22               | 4               |         |         |                   |
| 14      | 96100-60000-00    | 15.00                | Radial Ball Bearing 6000 (TPI) | 1               |         |         |                   |

PRICE SHOWN IS PER PIECE. PRODUCT IMAGE PRICES ARE APPROXIMATE GUIDE ONLY.  
 PRICES SHOWN ARE SUBJECT TO CHANGE WITHOUT PRIOR NOTICE.

E09

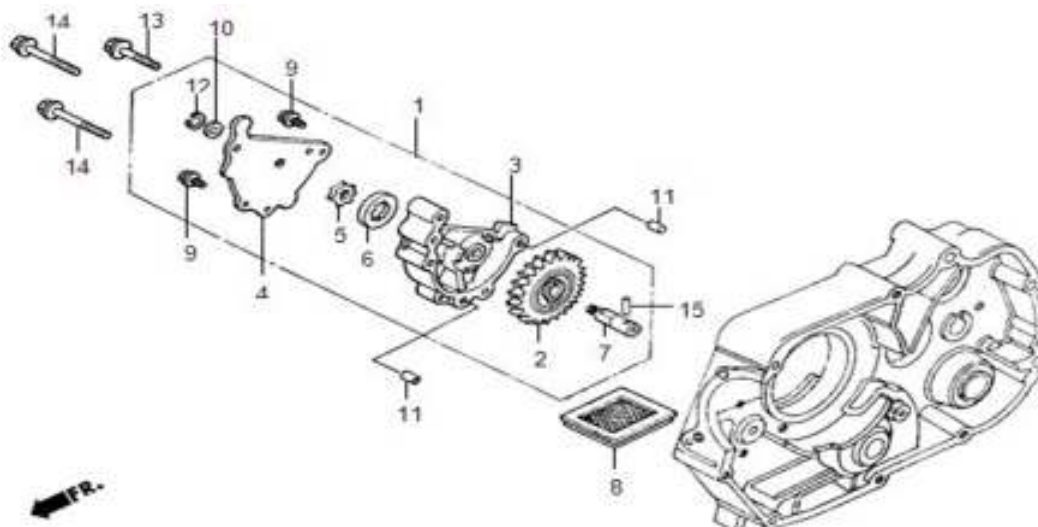
**OIL PUMP ASS'Y**  
**BỘ BƠM DẦU**

| STT No. | VMEP CODE      | SELLING PRICE RM/PCS | Tên phụ tùng<br>Description | S.lượng<br>Unit | STT No. | Mã E/C. | Ghi chú<br>Remark |
|---------|----------------|----------------------|-----------------------------|-----------------|---------|---------|-------------------|
| 1       | 15100-VA2-0004 | 48.80                | Oil Pump Ass'y              | 1               |         |         |                   |
| 2       | 15133-VA2-0001 | 16.50                | Oil Pump Driven Gear        | 1               |         |         |                   |
| 3       | 15311-VA2-0002 | 21.50                | Oil Pump Body               | 1               |         |         |                   |
| 4       | 15321-VA2-0002 | 19.60                | Oil Pump Body Cover         | 1               |         |         |                   |
| 5       | 15331-VA2-0001 | 9.80                 | Oil Pump Inner Rotor        | 1               |         |         |                   |
| 6       | 15332-VA2-0001 | 9.80                 | Oil Pump Outer Rotor        | 1               |         |         |                   |
| 7       | 15382-VA2-0001 | 35.20                | Oil Pump Driver Shaft       | 1               |         |         |                   |
| 8       | 15421-M8Q-0000 | 4.30                 | Oil Filter Screen           | 1               |         |         |                   |
| 9       | 90002-VA2-0000 | 0.70                 | Flange Bolt 5x10            | 2               |         |         |                   |
| 10      | 90444-VA2-0000 | 1.10                 | Thrust Washer 6 mm          | 1               |         |         |                   |
| 11      | 90702-VA2-000  | 1.40                 | Dowel Pin 8x12              | 2               |         |         |                   |
| 12      | 94540-05018    | 0.70                 | E-Ring 5 mm                 | 1               |         |         |                   |
| 13      | 95701-06035-00 | 0.80                 | Flange Bolt 6x35            | 1               |         |         |                   |
| 14      | 95701-06040-00 | 0.80                 | Flange Bolt 6x40            | 2               |         |         |                   |
| 15      | 96220-30158    | 0.70                 | Roller 3x15.8               | 1               |         |         |                   |

PRICE SHOWN IS PER PIECE. PRODUCT IMAGE PRICES ARE APPROXIMATE GUIDE ONLY.  
 PRICES SHOWN ARE SUBJECT TO CHANDE WITHOUT PRIOR NOTICE.

E10

## LEFT CRANK CASE COVER

NÁP MÁY BÊN TRÁI

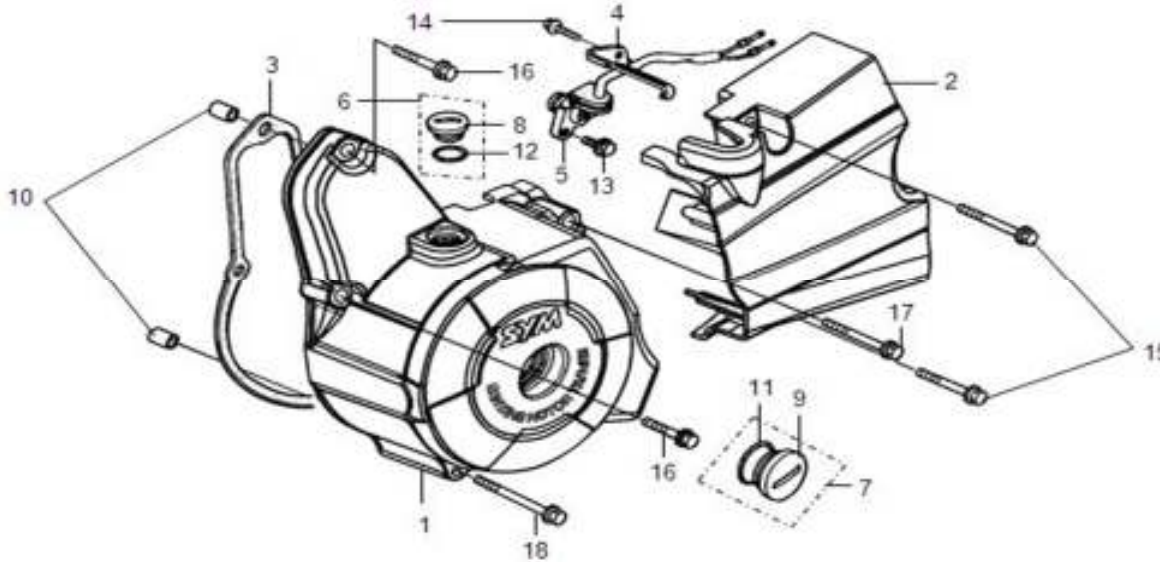

| STT No. | VMEP CODE         | SELLING PRICE RM/PCS | Tên phụ tùng<br>Description | S.lượng<br>Unit | STT No. | Mã E/C. | Ghi chú<br>Remark                       |
|---------|-------------------|----------------------|-----------------------------|-----------------|---------|---------|---|
| 1       | 11341-VA2-0000    | 83.00                | L. Crank Case Cover Comp.   | 1               |         |         |   |
| 2       | 11360-VA2-9000    | 31.40                | L. Crank Case Rear Cover    | 1               |         |         |   |
| 3       | 11395-VN7-0000    | 3.20                 | L. Crank Case Cover Gasket  | 1               |         |         |   |
| 4       | 32961-VA2-0000    | 1.80                 | A. C. G. Cord Clamber B     | 1               |         |         |   |
| 5       | 3575A-VA2-0002    | 17.20                | Change Switch Ass'y         | 1               |         |         | PARENT PART 3500T-VA2-0001              |
| 6       | 9008A-M8Q-0000    | 5.10                 | A.C.G. Cap Ass'y 14 mm      | 1               |         |         | PARENT PART                             |
| 7       | 9008B-M8Q-0000    | 7.50                 | A.C.G. Cap Ass'y 30 mm      | 1               |         |         | PARENT PART                             |
| 8       | 90084-M8Q-0000-IC | 2.40                 | A.C.G. Cap 14 mm            | 1               |         |         |   |
| 9       | 90087-M8Q-0000-IC | 2.60                 | A.C.G. Cap 30 mm            | 1               |         |         |   |
| 10      | 90702-VA2-000     | 1.40                 | Dowel Pin 8x12              | 2               |         |         |   |
| 11      | 91308-VA2-0000(X) |                      | O-Ring 27x2.0               | 1               |         |         | Please order parent part 9008B-M8Q-0000 |
| 12      | 91303-M2Q-0000    | 1.10                 | O-Ring 13.8x2.5             | 1               |         |         | Child part of 9008A-M8Q-0000            |
| 13      | 96001-06012-08    | 0.80                 | Sh. Flange Bolt 6x12        | 1               |         |         | PARENT PART 3500T-VA2-0001              |
| 14      | 96001-06016-00    | 0.70                 | Sh. Flange Bolt 6x16        | 1               |         |         |   |
| 15      | 96001-06028-07    | 0.70                 | Sh. Flange Bolt 6x28        | 2               |         |         |   |
| 16      | 96001-06032-08    | 0.70                 | Sh. Flange Bolt 6x32        | 2               |         |         |   |

PRICE SHOWN IS PER PIECE. PRODUCT IMAGE PRICES ARE APPROXIMATE GUIDE ONLY.  
PRICES SHOWN ARE SUBJECT TO CHANGE WITHOUT PRIOR NOTICE.

E10

**LEFT CRANK CASE COVER**  
**NÁP MÁY BÊN TRÁI**

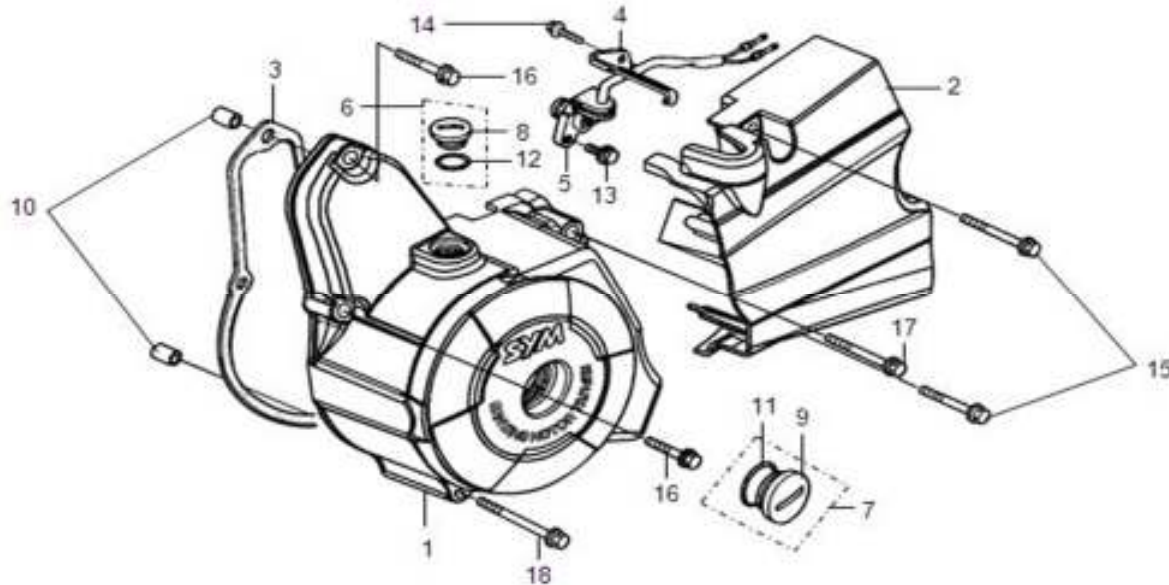

| STT No. | VMEP CODE      | SELLING PRICE RM/PCS | Tên phụ tùng<br>Description | S.lượng<br>Unit | STT No. | Mã E/C. | Ghi chú<br>Remark |
|---------|----------------|----------------------|-----------------------------|-----------------|---------|---------|-------------------|
| 17      | 96001-06050-00 | 0.80                 | Sh. Flange Bolt 6x50        | 1               |         |         |                   |
| 18      | 96001-06070-08 | 1.90                 | Sh. Flange Bolt 6x70        | 1               |         |         |                   |
|         |                |                      |                             |                 |         |         |                   |
|         |                |                      |                             |                 |         |         |                   |
|         |                |                      |                             |                 |         |         |                   |
|         |                |                      |                             |                 |         |         |                   |
|         |                |                      |                             |                 |         |         |                   |
|         |                |                      |                             |                 |         |         |                   |
|         |                |                      |                             |                 |         |         |                   |
|         |                |                      |                             |                 |         |         |                   |
|         |                |                      |                             |                 |         |         |                   |
|         |                |                      |                             |                 |         |         |                   |
|         |                |                      |                             |                 |         |         |                   |
|         |                |                      |                             |                 |         |         |                   |
|         |                |                      |                             |                 |         |         |                   |
|         |                |                      |                             |                 |         |         |                   |
|         |                |                      |                             |                 |         |         |                   |
|         |                |                      |                             |                 |         |         |                   |
|         |                |                      |                             |                 |         |         |                   |

PRICE SHOWN IS PER PIECE. PRODUCT IMAGE PRICES ARE APPROXIMATE GUIDE ONLY.  
PRICES SHOWN ARE SUBJECT TO CHANGE WITHOUT PRIOR NOTICE.

E11

**GENERATOR**  
**BỘ PHÁT ĐIỆN**

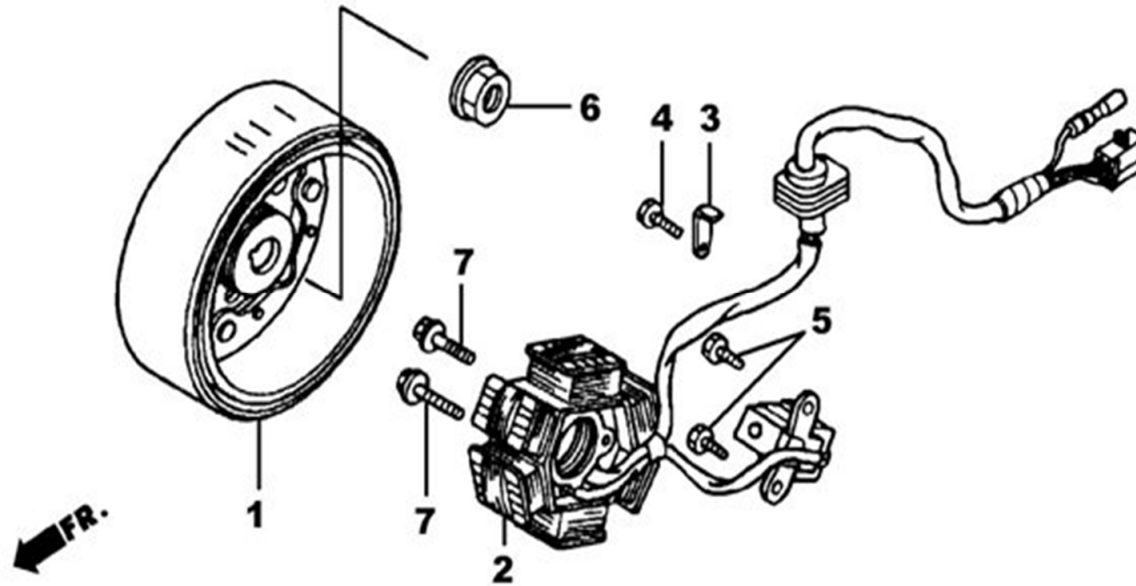

| STT No. | VMEP CODE      | SELLING PRICE RM/PCS | Tên phụ tùng<br>Description | S.lượng<br>Unit | STT No. | Mã E/C. | Ghi chú<br>Remark |
|---------|----------------|----------------------|-----------------------------|-----------------|---------|---------|-------------------|
| 1       | 3111A-VA2-0003 | 112.30               | Flywheel Comp.              | 1               |         |         |                   |
| 2       | 31120-VA2-0003 | 56.20                | Stator Comp.                | 1               |         |         |                   |
| 3       | 31141-VA2-0000 | 0.80                 | A.C Generator Cord Clamber  | 1               |         |         |                   |
| 4       | 93500-05006-0A | 0.40                 | Pan Screw 5x6               | 1               |         |         |                   |
| 5       | 93500-05010-0A | 0.40                 | Pan Screw 5x10              | 2               |         |         |                   |
| 6       | 94050-12000    | 2.40                 | Flange Nut 12 mm            | 1               |         |         |                   |
| 7       | 96001-06022-02 | 0.70                 | Sh. Flange Bolt 6x22        | 2               |         |         |                   |
|         |                |                      |                             |                 |         |         |                   |
|         |                |                      |                             |                 |         |         |                   |
|         |                |                      |                             |                 |         |         |                   |
|         |                |                      |                             |                 |         |         |                   |
|         |                |                      |                             |                 |         |         |                   |

PRICE SHOWN IS PER PIECE. PRODUCT IMAGE PRICES ARE APPROXIMATE GUIDE ONLY.  
PRICES SHOWN ARE SUBJECT TO CHANGE WITHOUT PRIOR NOTICE.

E12

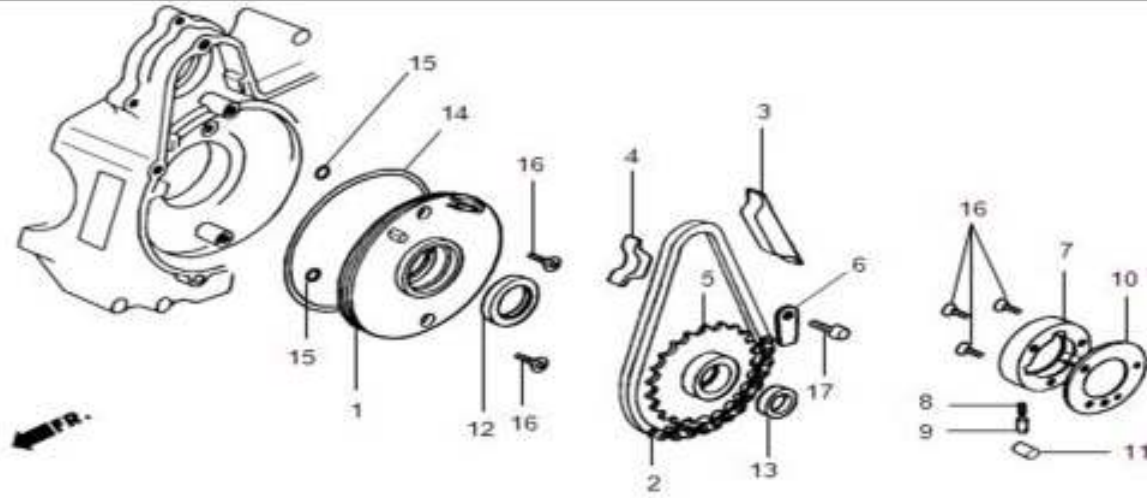
**STARTING CLUTCH**  
**LY HỢP KHỞI ĐỘNG**

| STT No. | VMEP CODE         | SELLING PRICE RM/PCS | Tên phụ tùng<br>Description   | S.lượng<br>Unit | STT No. | Mã E/C. | Ghi chú<br>Remark |
|---------|-------------------|----------------------|-------------------------------|-----------------|---------|---------|-------------------|
| 1       | 11321-A01-A000-VN | 10.30                | Oil Separate Cover            | 1               |         |         |                   |
| 2       | 1CS 25H X 62L     | 8.80                 | Starting Chain (62L)          | 1               |         |         |                   |
| 3       | 28102-M8Q-0000    | 3.50                 | Starter Chain Guide           | 1               |         |         |                   |
| 4       | 28103-M8Q-0000    | 2.90                 | Starter Chain Protector       | 1               |         |         |                   |
| 5       | 28110-A01-A001    | 47.60                | Starting Sprocket Comp.       | 1               |         |         |                   |
| 6       | 28117-A05-0000-VN | 2.10                 | Starting Sprocket Set Plate   | 1               |         |         |                   |
| 7       | 28120-A01-0000    | 63.60                | Starting Clutch Outer         | 1               |         |         |                   |
| 8       | 28125-M7Q-0001    | 2.10                 | Starting Clutch Roller Spring | 3               |         |         |                   |
| 9       | 28126-253-0305    | 4.10                 | Starting Roller Spring Cap    | 3               |         |         |                   |
| 10      | 28128-A01-A000-VN | 18.20                | Starting Cam Side Plate       | 1               |         |         |                   |
| 11      | 91101-M8Q-0000    | 2.00                 | Roller 10x10                  | 3               |         |         |                   |
| 12      | 91201-VA2-0000    | 3.70                 | Oil Seal 30x42x4.5            | 1               |         |         |                   |
| 13      | 91202-A01-0000    | 3.70                 | Oil Seal 18.9x30x5            | 1               |         |         |                   |
| 14      | 91302-VA2-0000    | 3.00                 | O-Ring 107x2                  | 1               |         |         |                   |
| 15      | 91318-VA2-0000    | 0.70                 | O-Ring 6.5x1.7                | 2               |         |         |                   |
| 16      | 93600-06016-OA    | 0.70                 | Flat Screw 6x16               | 5               |         |         |                   |
| 17      | 96001-06010-08    | 0.80                 | Sh. Flange Bolt 6x10          | 1               |         |         |                   |

PRICE SHOWN IS PER PIECE. PRODUCT IMAGE PRICES ARE APPROXIMATE GUIDE ONLY.  
 PRICES SHOWN ARE SUBJECT TO CHANGE WITHOUT PRIOR NOTICE.

E13

**STARTING MOTOR**  
**MÔ-TƠ KHỞI ĐỘNG**

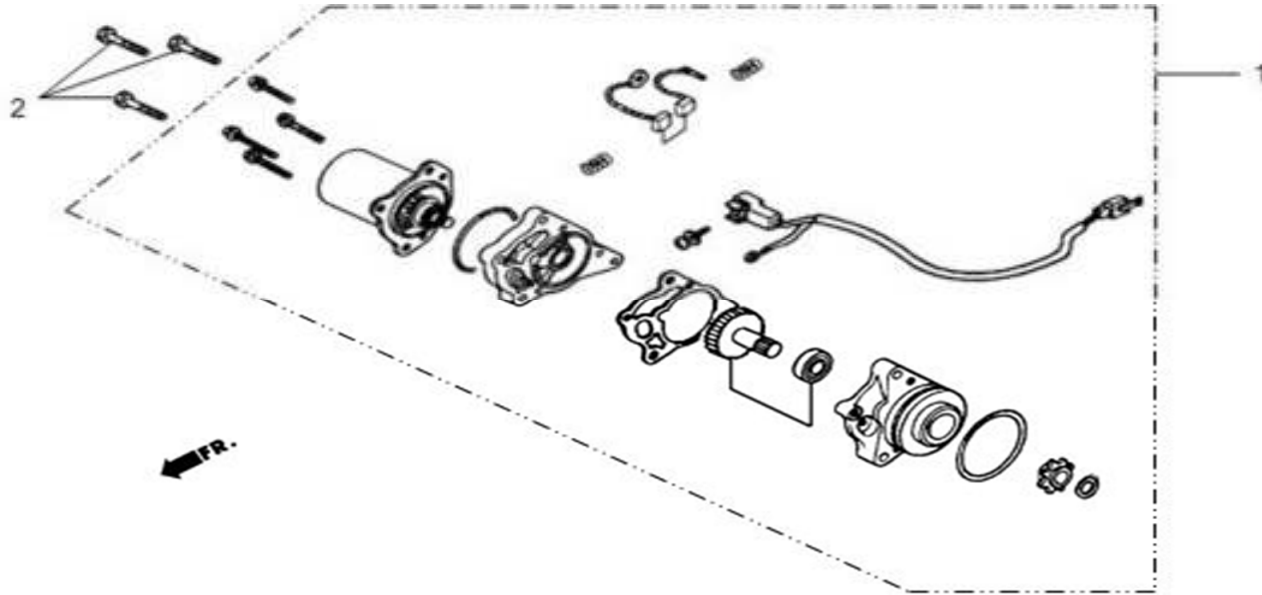

| STT No. | VMEP CODE      | SELLING PRICE RM/PCS | Tên phụ tùng<br>Description | S.lượng<br>Unit | STT No. | Mã E/C. | Ghi chú<br>Remark |
|---------|----------------|----------------------|-----------------------------|-----------------|---------|---------|-------------------|
| 1       | 31200-VA2-0003 | 125.00               | Start Motor Ass'y           | 1               |         |         |                   |
| 2       | 96001-06050-00 | 0.80                 | Flange Bolt 6x50            | 3               |         |         |                   |
|         |                |                      |                             |                 |         |         |                   |
|         |                |                      |                             |                 |         |         |                   |
|         |                |                      |                             |                 |         |         |                   |
|         |                |                      |                             |                 |         |         |                   |
|         |                |                      |                             |                 |         |         |                   |
|         |                |                      |                             |                 |         |         |                   |
|         |                |                      |                             |                 |         |         |                   |
|         |                |                      |                             |                 |         |         |                   |
|         |                |                      |                             |                 |         |         |                   |
|         |                |                      |                             |                 |         |         |                   |
|         |                |                      |                             |                 |         |         |                   |
|         |                |                      |                             |                 |         |         |                   |
|         |                |                      |                             |                 |         |         |                   |
|         |                |                      |                             |                 |         |         |                   |

PRICE SHOWN IS PER PIECE. PRODUCT IMAGE PRICES ARE APPROXIMATE GUIDE ONLY.  
PRICES SHOWN ARE SUBJECT TO CHANDE WITHOUT PRIOR NOTICE.



E14

**CRANK CASE**  
**HỘP TRỤC KHUYU**

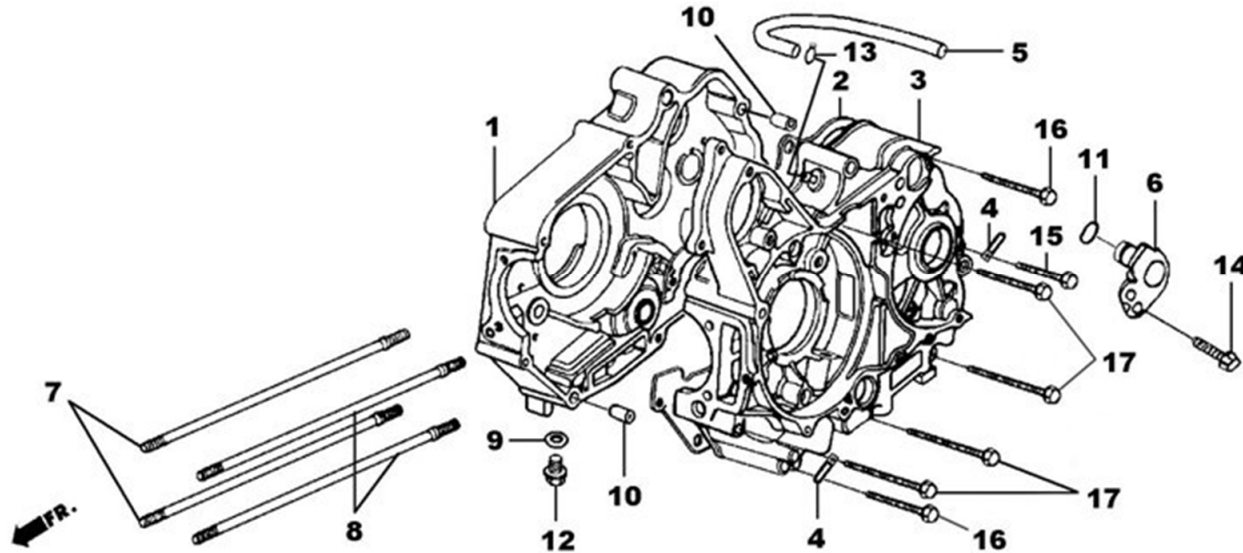

| STT No. | VMEP CODE         | SELLING PRICE RM/PCS | Tên phụ tùng<br>Description  | S.lượng<br>Unit | STT No. | Mã E/C. | Ghi chú<br>Remark                                |
|---------|-------------------|----------------------|------------------------------|-----------------|---------|---------|--|
| 1       | 11100-VDA-0002    | 187.80               | R. Crank Case Comp.          | 1               |         |         |  |
| 2       | 11191-VN7-0000    | 4.10                 | Crank Case Gasket            | 1               |         |         |  |
| 3       | 11200-SAB-0000-F2 | 175.90               | L. Crank Case Comp.          | 1               |         |         |  |
| 4       | 12342-X01-0000    | 1.10                 | Clamp                        | 2               |         |         |  |
| 5       | 1576A-VA2-0006(X) |                      | Breather Tube                | 1               |         |         | Please order parent part 1576A-VA2-0001 (RM3.70) |
| 6       | 24331-VA2-0000    | 4.10                 | Contact Switch Block         | 1               |         |         | PARENT PART 3500T-VA2-0001                       |
| 7       | 90031-VA1-0002    | 4.50                 | Cylinder Stud Bolt 6x206.5x7 | 2               |         |         |  |
| 8       | 90032-VA1-0002    | 4.50                 | Cylinder Stud Bolt 6x214.5x7 | 2               |         |         |  |
| 9       | 90407-SB1-0000    | 0.70                 | Drain Cock Parking 12.5x20   | 1               |         |         |  |
| 10      | 90703-HC4-0000    | 1.40                 | Dowel Pin 10x14              | 2               |         |         |  |
| 11      | 91301-VA2-0000    | 0.70                 | O-Ring 22x2                  | 1               |         |         |  |
| 12      | 92800-12000       | 2.60                 | Drain Plug Bolt 12 mm        | 1               |         |         |  |
| 13      | 95002-70000(X)    |                      | Tube Clip C11                | 1               |         |         | Please order parent part 1576A-VA2-0001 (RM3.70) |
| 14      | 96001-06025-00    | 0.70                 | Sh. Flange Bolt 6x25         | 1               |         |         |  |
| 15      | 96001-06050-00    | 0.80                 | Sh. Flange Bolt 6x50         | 1               |         |         |  |
| 16      | 96001-06060-08    | 1.80                 | Sh. Flange Bolt 6x60         | 2               |         |         |  |
| 17      | 96001-06065-00    | 1.80                 | Sh. Flange Bolt 6x65         | 4               |         |         |  |

PRICE SHOWN IS PER PIECE. PRODUCT IMAGE PRICES ARE APPROXIMATE GUIDE ONLY.  
PRICES SHOWN ARE SUBJECT TO CHANGE WITHOUT PRIOR NOTICE.

E15

## CRANK SHAFT - PISTON

BỘ TRỤC KHUỖU - PISTON

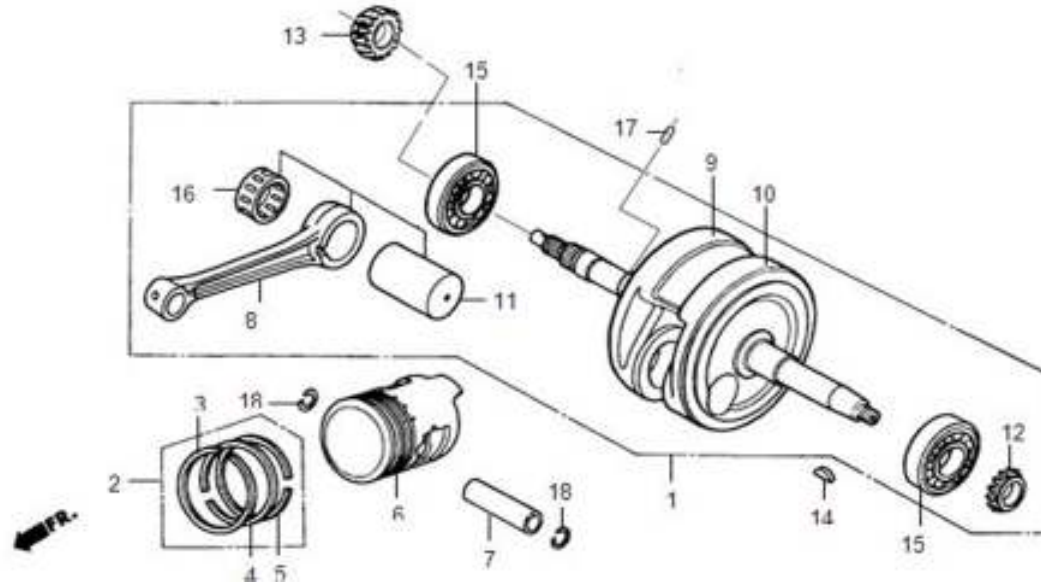

| STT No. | VMEP CODE      | SELLING PRICE RM/PCS | Tên phụ tùng<br>Description | S.lượng<br>Unit | STT No. | Mã E/C. | Ghi chú<br>Remark |
|---------|----------------|----------------------|-----------------------------|-----------------|---------|---------|-------------------|
| 1       | 13000-VA1-0002 | 359.40               | Crank Shaft Comp.           | 1               |         |         | PARENT PART       |
| 2       | 13010-VA2-0000 | 27.00                | Piston Ring Set (STD.)      | 1               |         |         |                   |
|         | 13012-VA2-3050 | 28.80                | Piston Ring Set (0.25)      | 1               |         |         |                   |
|         | 13013-VA2-3050 | 30.70                | Piston Ring Set (0.50)      | 1               |         |         |                   |
|         | 13014-VA2-3050 | 32.60                | Piston Ring Set (0.75)      | 1               |         |         |                   |
|         | 13015-VA2-3050 | 34.50                | Piston Ring Set (1.00)      | 1               |         |         |                   |
| 3       | 13121-VA2-000  |                      | Piston Top Ring             | 1               |         |         |                   |
| 4       | 13131-A31-000  |                      | Piston 2nd Ring             | 1               |         |         |                   |
| 5       | 13141-VA2-000  |                      | Piston Oil Ring             | 1               |         |         |                   |
| 6       | 13101-VA2-0000 | 30.00                | Piston (STD.)               | 1               |         |         |                   |
|         | 13102-VA2-3050 | 31.90                | Piston (0.25)               | 1               |         |         |                   |
|         | 13103-VA2-3050 | 33.70                | Piston (0.50)               | 1               |         |         |                   |
|         | 13104-VA2-3050 | 35.60                | Piston (0.75)               | 1               |         |         |                   |
|         | 13105-VA2-3050 | 37.50                | Piston (1.00)               | 1               |         |         |                   |
| 7       | 13111-A04-A000 | 4.10                 | Piston Pin                  | 1               |         |         |                   |
| 8       | 13201-VA1-0001 | 58.60                | Connecting Rod              | 1               |         |         |                   |

PRICE SHOWN IS PER PIECE. PRODUCT IMAGE PRICES ARE APPROXIMATE GUIDE ONLY.  
PRICES SHOWN ARE SUBJECT TO CHANGE WITHOUT PRIOR NOTICE.

E15

**CRANK SHAFT - PISTON**  
**BỘ TRỤC KHUỖU - PISTON**

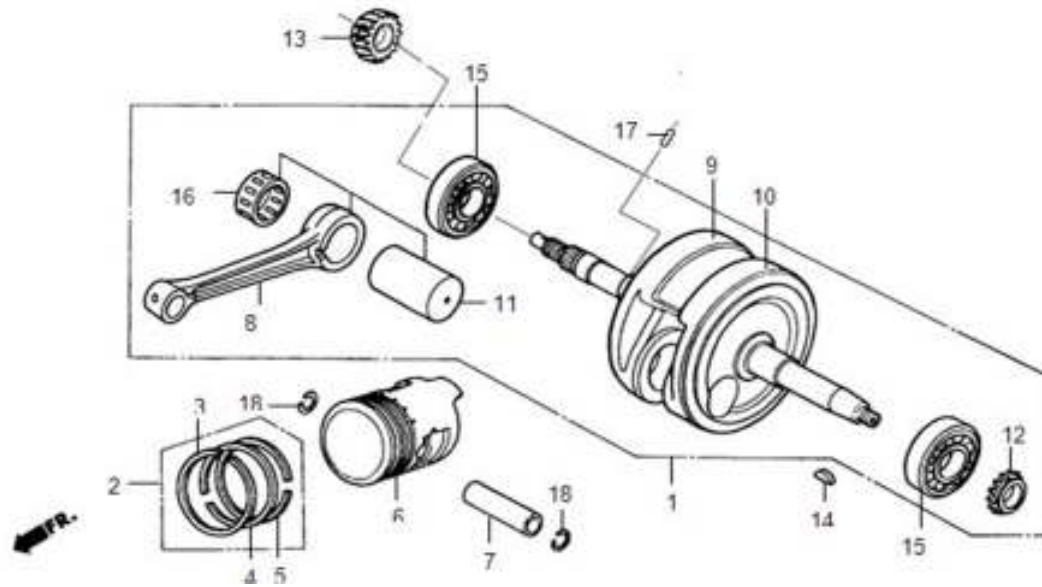

| STT No. | VMEP CODE      | SELLING PRICE RM/PCS | Tên phụ tùng<br>Description     | S.lượng<br>Unit | STT No. | Mã E/C. | Ghi chú<br>Remark                       |
|---------|----------------|----------------------|---------------------------------|-----------------|---------|---------|---|
| 9       | 13310-VD3-3002 |                      | R. Crank Shaft Comp.            | 1               |         |         | Please order parent part 13000-VA1-0002 |
| 10      | 13321-VD3-3003 |                      | L. Crank Shaft                  | 1               |         |         | Please order parent part 13000-VA1-0002 |
| 11      | 13381-VA2-3001 | 19.60                | Crank Pin                       | 1               |         |         |   |
| 12      | 14311-VA2-3000 | 16.30                | Timing Sprocket (16T)           | 1               |         |         |   |
| 13      | 15341-VA2-0001 | 19.60                | Oil Pump Driver Gear            | 1               |         |         |   |
| 14      | 90741-M8Q-0000 | 2.60                 | Key Woodruff 4 mm               | 1               |         |         |   |
| 15      | 91001-M36-0001 | 26.20                | Radial Ball Brearing 6304 (TPI) | 2               |         |         |   |
| 16      | 91002-VA2-0000 | 18.70                | Con-Rod Big End Bearing         | 1               |         |         |   |
| 17      | 94303-03050    | 0.80                 | Dowel Pin 3x5                   | 1               |         |         |   |
| 18      | 94601-13000-00 | 0.40                 | Piston Pin Clip 13 mm           | 2               |         |         |   |
|         |                |                      |                                 |                 |         |         |   |
|         |                |                      |                                 |                 |         |         |   |
|         |                |                      |                                 |                 |         |         |   |
|         |                |                      |                                 |                 |         |         |   |

PRICE SHOWN IS PER PIECE. PRODUCT IMAGE PRICES ARE APPROXIMATE GUIDE ONLY.  
PRICES SHOWN ARE SUBJECT TO CHANDE WITHOUT PRIOR NOTICE.

E16

**TRANSMISSION**  
**BỘ SỐ**

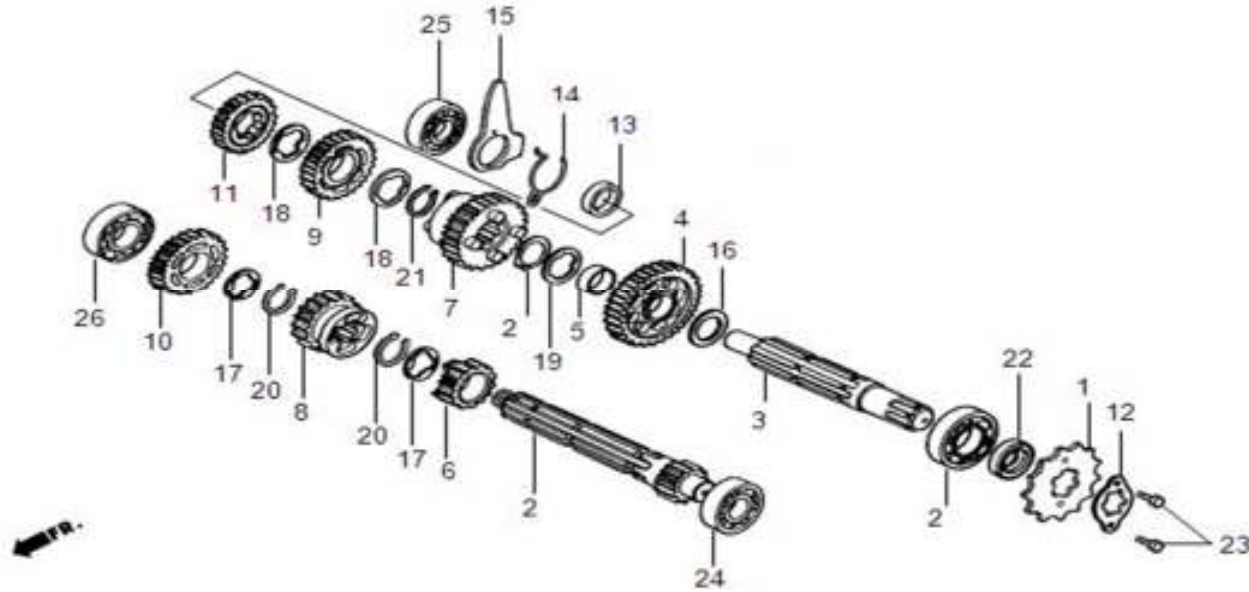

| STT No. | VMEP CODE      | SELLING PRICE RM/PCS | Tên phụ tùng<br>Description | S.lượng<br>Unit | STT No. | Mã E/C. | Ghi chú<br>Remark |
|---------|----------------|----------------------|-----------------------------|-----------------|---------|---------|-------------------|
| 1       | 22711-SB1-0000 | 7.50                 | Drive Sprocket (14T)        | 1               |         |         |                   |
| 2       | 23211-VA2-0000 | 63.60                | Main Shaft (12T)            | 1               |         |         |                   |
| 3       | 23221-VA2-0001 | 33.70                | Counter Shaft               | 1               |         |         |                   |
| 4       | 23421-VA2-0001 | 37.10                | C-1 Gear (34T)              | 1               |         |         |                   |
| 5       | 23422-VA2-0000 | 3.70                 | Bush 20x9                   | 1               |         |         |                   |
| 6       | 23431-VA2-0000 | 33.00                | M-2 Gear (17T)              | 1               |         |         |                   |
| 7       | 23441-VA2-0001 | 33.70                | C-2 Gear (29T)              | 1               |         |         |                   |
| 8       | 23451-VA2-0000 | 37.50                | M-3 Gear (21T)              | 1               |         |         |                   |
| 9       | 23461-VA2-0000 | 41.20                | C-3 Gear (26T)              | 1               |         |         |                   |
| 10      | 23471-VA2-0000 | 41.20                | M-4 Gear (24T)              | 1               |         |         |                   |
| 11      | 23481-VA2-0001 | 41.20                | C-4 Gear (23T)              | 1               |         |         |                   |
| 12      | 23802-M36-0000 | 1.20                 | Drive Sprocket Fixing Plate | 1               |         |         |                   |
| 13      | 23911-VA2-0000 | 0.80                 | Collar                      | 1               |         |         |                   |
| 14      | 24305-VA2-0001 | 1.70                 | Gear Shift Drum Lock Spring | 1               |         |         |                   |
| 15      | 24306-VA2-0000 | 4.10                 | Gear Shift Drum Lock Plate  | 1               |         |         |                   |
| 16      | 90452-VA2-0000 | 0.70                 | Thrust Washer 17 mm         | 1               |         |         |                   |

PRICE SHOWN IS PER PIECE. PRODUCT IMAGE PRICES ARE APPROXIMATE GUIDE ONLY.  
PRICES SHOWN ARE SUBJECT TO CHANGE WITHOUT PRIOR NOTICE.

E16

**TRANSMISSION**  
**BỘ SỐ**

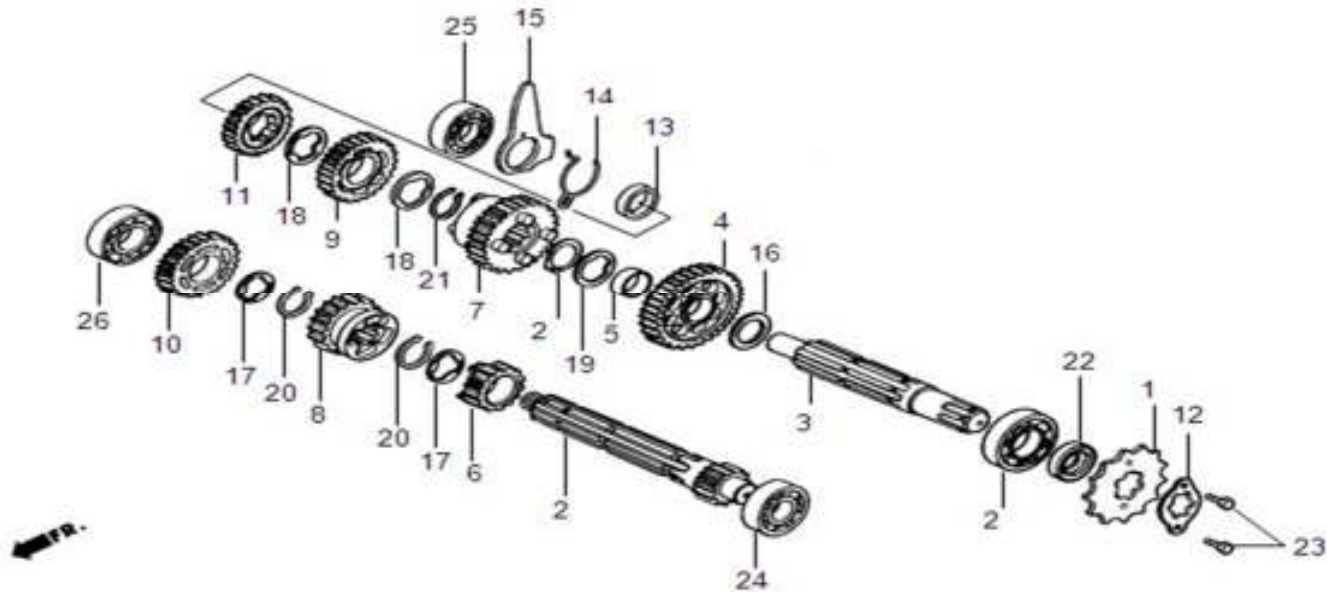

| STT No. | VMEP CODE      | SELLING PRICE RM/PCS | Tên phụ tùng<br>Description    | S.lượng<br>Unit | STT No. | Mã E/C. | Ghi chú<br>Remark |
|---------|----------------|----------------------|--------------------------------|-----------------|---------|---------|-------------------|
| 17      | 90461-VA2-0001 | 0.70                 | Spline Washer 17 mm            | 2               |         |         |                   |
| 18      | 90462-VA2-0000 | 1.10                 | Spline Washer 20 mm            | 2               |         |         |                   |
| 19      | 90463-VA2-0000 | 1.80                 | Spline Washer 20x1.2           | 1               |         |         |                   |
| 20      | 90601-A08-0001 | 1.10                 | Ex. Cir-Clip 17 mm             | 2               |         |         |                   |
| 21      | 90605-A08-0002 | 1.60                 | Set Ring 20 mm                 | 2               |         |         |                   |
| 22      | 91203-VA2-0000 | 2.20                 | Oil Seal 17x29x5               | 1               |         |         |                   |
| 23      | 92101-06010-OH | 0.40                 | Hex Bolt 6x10                  | 2               |         |         |                   |
| 24      | 96100-60010-00 | 5.90                 | Radial Ball Bearing 6001 (TPI) | 1               |         |         |                   |
| 25      | 96100-62010-00 | 8.60                 | Radial Ball Bearing 6201 (TPI) | 1               |         |         |                   |
| 26      | 96100-62030-00 | 9.70                 | Radial Ball Bearing 6203 (TPI) | 2               |         |         |                   |
|         |                |                      |                                |                 |         |         |                   |
|         |                |                      |                                |                 |         |         |                   |
|         |                |                      |                                |                 |         |         |                   |
|         |                |                      |                                |                 |         |         |                   |
|         |                |                      |                                |                 |         |         |                   |

PRICE SHOWN IS PER PIECE. PRODUCT IMAGE PRICES ARE APPROXIMATE GUIDE ONLY.  
PRICES SHOWN ARE SUBJECT TO CHANGE WITHOUT PRIOR NOTICE.

E17

**GEAR SHIFT DRUM**  
**TRỐNG SỐ**

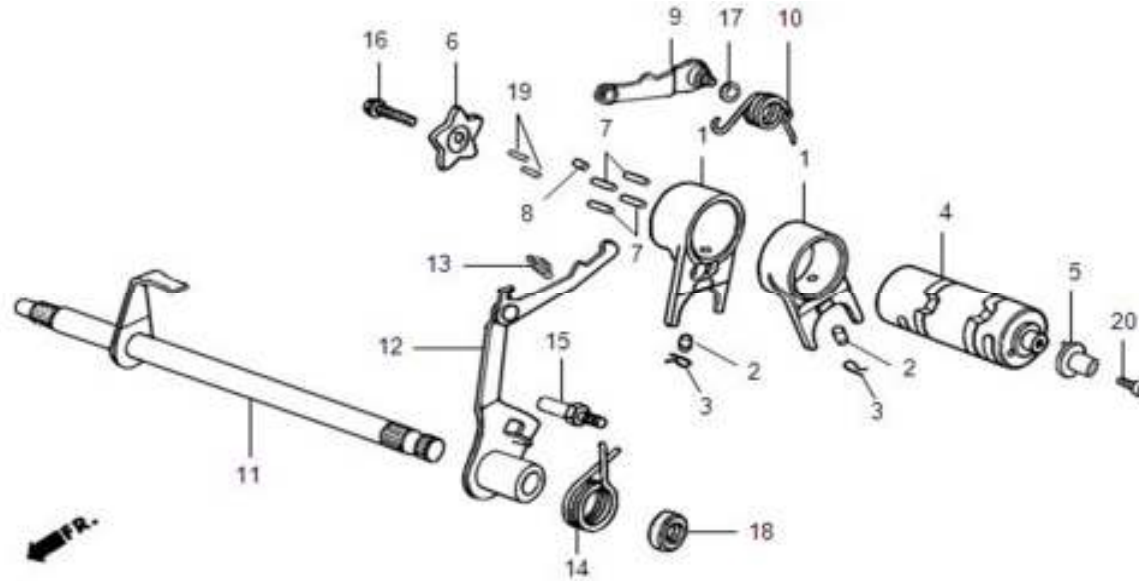

| STT No. | VMEP CODE         | SELLING PRICE RM/PCS | Tên phụ tùng<br>Description    | S.lượng<br>Unit | STT No. | Mã E/C. | Ghi chú<br>Remark                       |
|---------|-------------------|----------------------|--------------------------------|-----------------|---------|---------|---|
| 1       | 24211-VA2-0001    | 37.10                | Gear Shift Fork                | 2               |         |         | PARENT PART 2430A-VA2-0004              |
| 2       | 24261-VA2-0000    | 2.10                 | Gear Shift Fork Guide Pin      | 2               |         |         | PARENT PART 2430A-VA2-0004              |
| 3       | 24263-M8Q-0000    | 1.20                 | Gear Shift Fork Guide Pin Clip | 2               |         |         | PARENT PART 2430A-VA2-0004              |
| 4       | 24301-VA2-0002    | 56.20                | Gear Shift Drum                | 1               |         |         | PARENT PART 2430A-VA2-0004              |
| 5       | 24320-VA2-0000    | 3.20                 | Contact Drive Plate Comp.      | 1               |         |         |   |
| 6       | 24411-VA2-0001    | 2.10                 | Gear Shift Cam                 | 1               |         |         | PARENT PART 2430A-VA2-0004              |
| 7       | 24421-VA2-0000    | 1.20                 | Gear Shift Drum Pin            | 4               |         |         | PARENT PART 2430A-VA2-0004              |
| 8       | 24422-VA2-0000    | 1.20                 | Gear Shift Drum Pin 8.7 mm     | 1               |         |         | PARENT PART 2430A-VA2-0004              |
| 9       | 24430-VA2-0002    | 4.10                 | Shift Drum Stopper Comp.       | 1               |         |         |   |
| 10      | 24435-VA2-0001    | 1.20                 | Gear Shift Drum Stopper Spring | 1               |         |         |   |
| 11      | 24610-VA2-3002    | 37.50                | Gear Shift Spindle Comp.       | 1               |         |         |   |
| 12      | 24630-VA2-0003    | 28.10                | Gear Shift Arm Comp.           | 1               |         |         |   |
| 13      | 24641-M8Q-0000(X) |                      | Gear Shift Arm Spring          | 1               |         |         | Please order parent part 24630-VA2-0003 |
| 14      | 24651-M8Q-0000    | 2.40                 | Gear Shift Return Spring       | 1               |         |         |   |
| 15      | 24652-M36-0000    | 4.00                 | Shift Arm Stopper Pin          | 1               |         |         |   |
| 16      | 90071-M8Q-0000    | 0.70                 | Knock Bolt 6 mm                | 1               |         |         | PARENT PART 2430A-VA2-0004              |

PRICE SHOWN IS PER PIECE. PRODUCT IMAGE PRICES ARE APPROXIMATE GUIDE ONLY.  
PRICES SHOWN ARE SUBJECT TO CHANGE WITHOUT PRIOR NOTICE.

E17

**GEAR SHIFT DRUM**  
**TRÓNG SÓ**

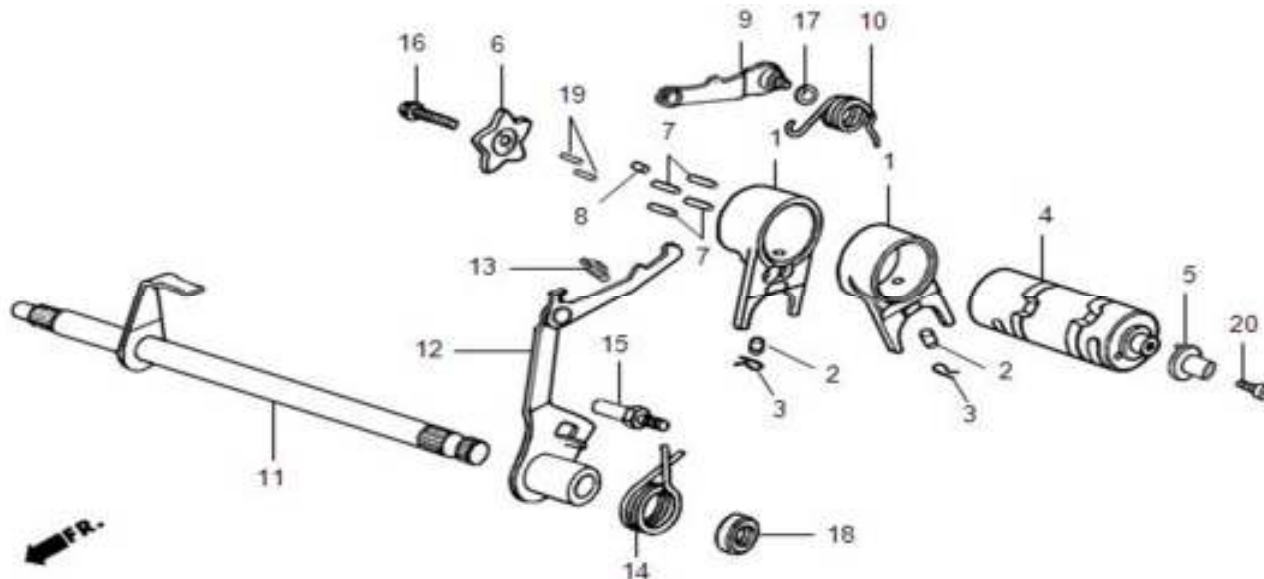

| STT No. | VMEP CODE      | SELLING PRICE RM/PCS | Tên phụ tùng<br>Description | S.lượng<br>Unit | STT No. | Mã E/C. | Ghi chú<br>Remark          |
|---------|----------------|----------------------|-----------------------------|-----------------|---------|---------|----------------------------|
| 17      | 90479-X01-0000 | 0.70                 | Washer 6 mm                 | 1               |         |         |                            |
| 18      | 91208-VA2-0000 | 2.20                 | Oil Seal 11.6x24x10         | 1               |         |         |                            |
| 19      | 96220-30085    | 0.70                 | Roller 3x8.5                | 2               |         |         | PARENT PART 2430A-VA2-0004 |
| 20      | 96700-06016-00 | 0.70                 | Socket Bolt 6x16            | 1               |         |         |                            |
|         |                |                      |                             |                 |         |         |                            |
|         |                |                      |                             |                 |         |         |                            |
|         |                |                      |                             |                 |         |         |                            |
|         |                |                      |                             |                 |         |         |                            |
|         |                |                      |                             |                 |         |         |                            |
|         |                |                      |                             |                 |         |         |                            |
|         |                |                      |                             |                 |         |         |                            |
|         |                |                      |                             |                 |         |         |                            |
|         |                |                      |                             |                 |         |         |                            |
|         |                |                      |                             |                 |         |         |                            |
|         |                |                      |                             |                 |         |         |                            |
|         |                |                      |                             |                 |         |         |                            |

PRICE SHOWN IS PER PIECE. PRODUCT IMAGE PRICES ARE APPROXIMATE GUIDE ONLY.  
PRICES SHOWN ARE SUBJECT TO CHANGE WITHOUT PRIOR NOTICE.

E18

**KICK STARTER SPINDLE**  
TRỤC KHỞI ĐỘNG

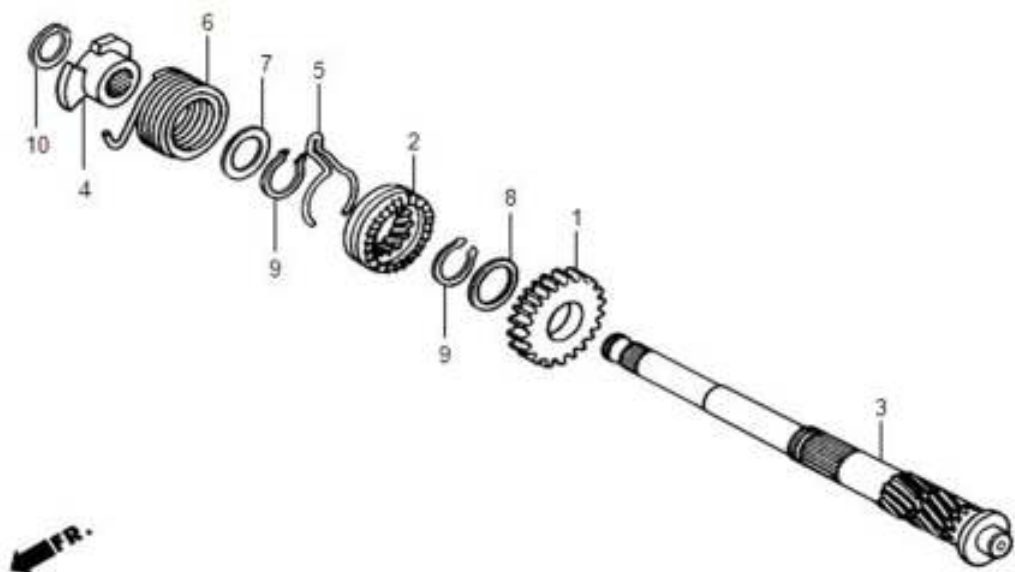

| STT No. | VMEP CODE      | SELLING PRICE RM/PCS | Tên phụ tùng<br>Description    | S.lượng<br>Unit | STT No. | Mã E/C. | Ghi chú<br>Remark |
|---------|----------------|----------------------|--------------------------------|-----------------|---------|---------|-------------------|
| 1       | 28211-178-0000 | 16.40                | Kick Starter Pinion (22T)      | 1               |         |         |                   |
| 2       | 28221-A13-0000 | 12.30                | Starter Drive Ratchet          | 1               |         |         |                   |
| 3       | 28251-VA2-0000 | 37.10                | Kick Starter Spindle           | 1               |         |         |                   |
| 4       | 28262-A01-A000 | 3.00                 | Kick Spring Retainer           | 1               |         |         |                   |
| 5       | 28271-121-6900 | 3.00                 | Starter Pinion Friction Spring | 1               |         |         |                   |
| 6       | 28281-035-0180 | 3.70                 | Kick Starter Spring            | 1               |         |         |                   |
| 7       | 90452-VA2-0000 | 0.70                 | Washer 17 mm                   | 1               |         |         |                   |
| 8       | 90454-B04-0002 | 0.40                 | Thruster Washer 20 mm          | 1               |         |         |                   |
| 9       | 90605-A08-0002 | 1.60                 | Set Ring 20 mm                 | 2               |         |         |                   |
| 10      | 94510-16000-00 | 2.10                 | Cir-Clip 16 mm                 | 1               |         |         |                   |
|         |                |                      |                                |                 |         |         |                   |
|         |                |                      |                                |                 |         |         |                   |
|         |                |                      |                                |                 |         |         |                   |

PRICE SHOWN IS PER PIECE. PRODUCT IMAGE PRICES ARE APPROXIMATE GUIDE ONLY.  
PRICES SHOWN ARE SUBJECT TO CHANDE WITHOUT PRIOR NOTICE.



E19

**CARBURETOR ASS'Y**  
**BỘ CHẾ HÒA KHÍ**

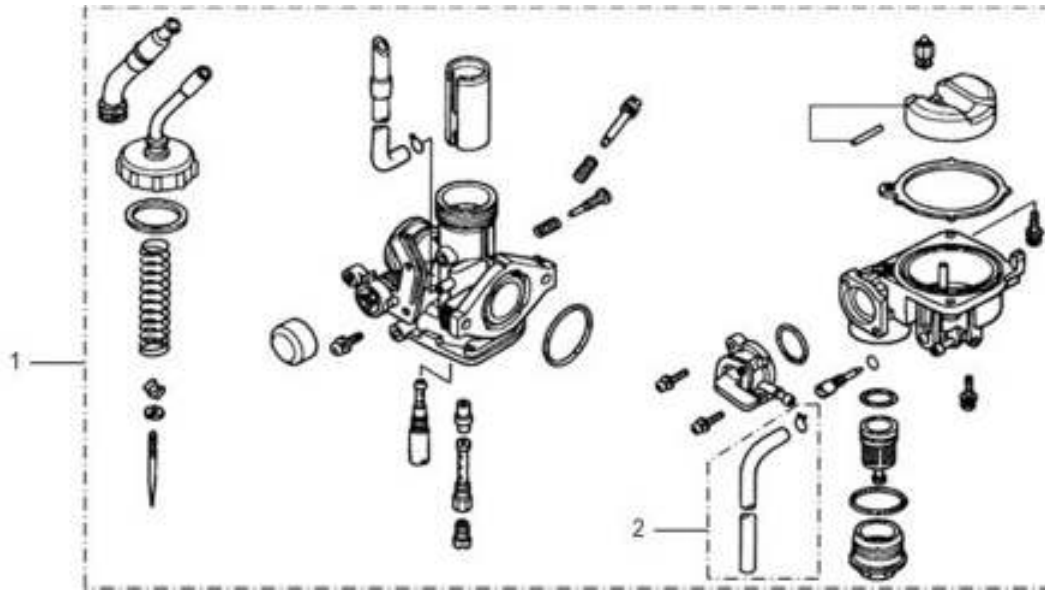

| STT No. | VMEP CODE         | SELLING PRICE RM/PCS | Tên phụ tùng<br>Description | S.lượng<br>Unit | STT No. | Mã E/C. | Ghi chú<br>Remark |
|---------|-------------------|----------------------|-----------------------------|-----------------|---------|---------|-------------------|
| 1       | 16100-A04-A003-VN | 229.20               | Carburetor Ass'y            | 1               |         |         |                   |
| 2       | 16101-VA6-0000    | 1.30                 | Rubber Tube Ass'y           | 1               |         |         |                   |
|         |                   |                      |                             |                 |         |         |                   |
|         |                   |                      |                             |                 |         |         |                   |
|         |                   |                      |                             |                 |         |         |                   |
|         |                   |                      |                             |                 |         |         |                   |
|         |                   |                      |                             |                 |         |         |                   |
|         |                   |                      |                             |                 |         |         |                   |
|         |                   |                      |                             |                 |         |         |                   |
|         |                   |                      |                             |                 |         |         |                   |
|         |                   |                      |                             |                 |         |         |                   |
|         |                   |                      |                             |                 |         |         |                   |
|         |                   |                      |                             |                 |         |         |                   |

PRICE SHOWN IS PER PIECE. PRODUCT IMAGE PRICES ARE APPROXIMATE GUIDE ONLY.  
 PRICES SHOWN ARE SUBJECT TO CHANGE WITHOUT PRIOR NOTICE.

F01

**HEAD LIGHT  
ĐÈN TRƯỚC**

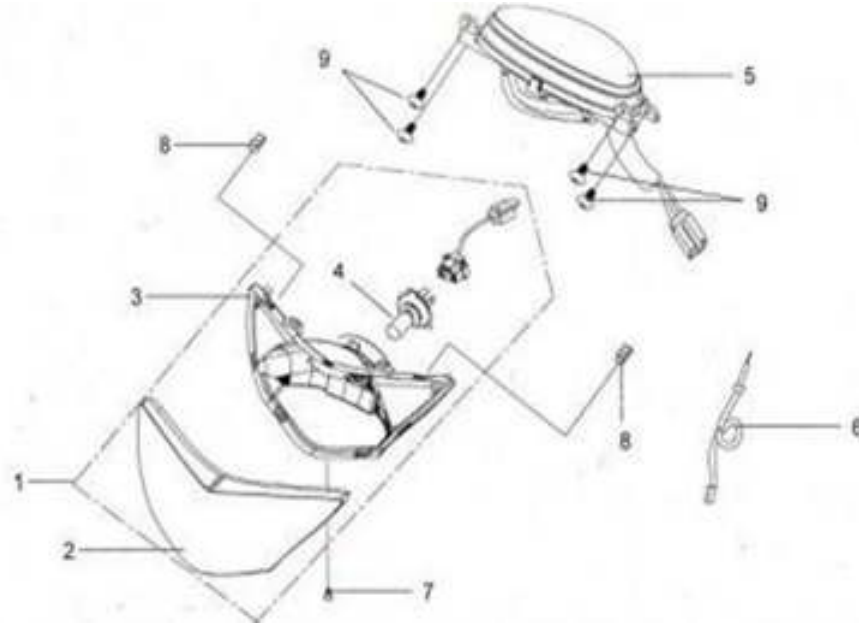

| STT No. | VMEP CODE      | SELLING PRICE RM/PCS | Tên phụ tùng<br>Description | Số lượng<br>Unit | STT No. | Mã E/C. | Ghi chú<br>Remark |
|---------|----------------|----------------------|-----------------------------|------------------|---------|---------|-------------------|
| 1       | 33100-SAF-0001 | 63.60                | Head Light Ass'y            | 1                |         |         |                   |
| 2       | 33102-SAF-0000 | 16.80                | Head Light Lens             | 1                |         |         |                   |
| 3       | 33106-SAF-0000 | 40.90                | Head Light Base             | 1                |         |         |                   |
| 4       | 34901-SA5-0000 | 13.00                | Head Light Bulb             | 1                |         |         |                   |
| 5       | 37200-SAH-0000 | 104.80               | Speedometer Ass'y           | 1                |         |         |                   |
| 6       | 44830-SA5-0000 | 8.20                 | Speedometer Cable Comp.     | 1                |         |         |                   |
| 7       | 90101-VD3-0001 | 0.70                 | Adjust Bolt                 | 1                |         |         |                   |
| 8       | 90651-T36-0000 | 0.70                 | Head Light Clip             | 2                |         |         |                   |
| 9       | 93903-35220-00 | 0.60                 | Tapping Screw 5x12          | 4                |         |         |                   |
| 10      | 37211-SAF-0000 | 14.70                | Meter Lens                  | 1                |         |         |                   |
|         |                |                      |                             |                  |         |         |                   |
|         |                |                      |                             |                  |         |         |                   |

PRICE SHOWN IS PER PIECE. PRODUCT IMAGE PRICES ARE APPROXIMATE GUIDE ONLY.  
PRICES SHOWN ARE SUBJECT TO CHANGE WITHOUT PRIOR NOTICE.

F02

**FRONT BRAKE-BACK MIRROR**  
**THẮNG TRƯỚC-KÍNH CHIẾU HẬU**

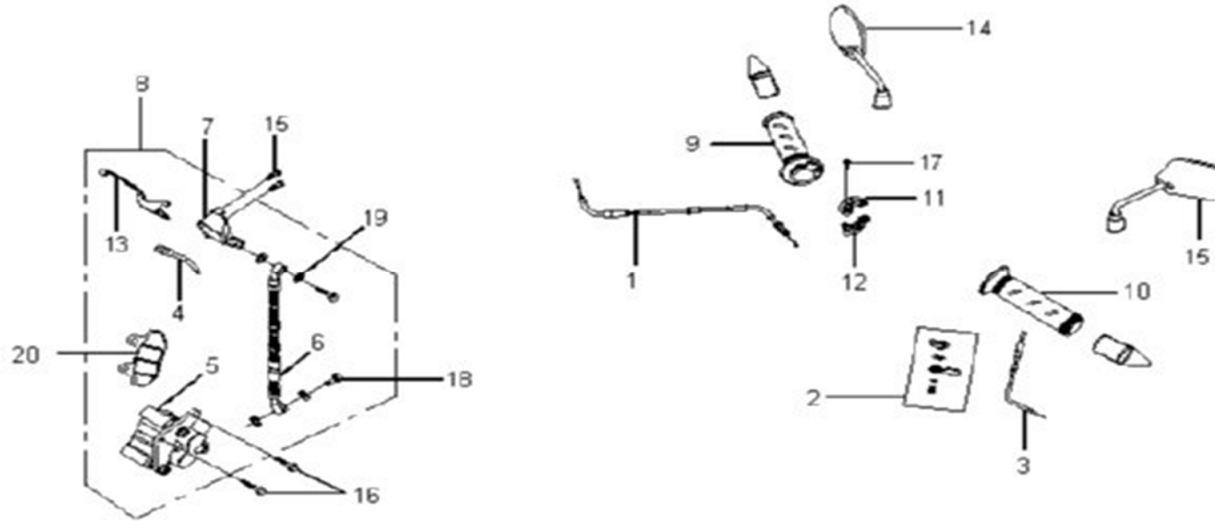

| STT No. | VMEP CODE         | SELLING PRICE RM/PCS | Tên phụ tùng Description | Số lượng Unit | STT No. | Mã E/C. | Ghi chú Remark                  |
|---------|-------------------|----------------------|--------------------------|---------------|---------|---------|---------------------------------|
| 1       | 17910-SAH-0000    | 6.00                 | Throttle Cable Comp.     | 1             |         |         |                                 |
| 2       | 1795A-VAH-0000    | 5.60                 | Chock Lever Comp         | 1             |         |         |                                 |
| 3       | 17950-VAH-A000    | 5.60                 | Choke Cable Comp.        | 1             |         |         |                                 |
| 4       | 35342-M3G-0000    | 5.00                 | Fr. Stop SW. Cord Comp   | 1             |         |         |                                 |
| 5       | 45100-SAB-0001    | 175.20               | Fr. Caliper Assy         | 1             |         |         | CHILD PART OF 4550A-SAR-0001-VN |
| 6       | 45126-SAR-0000    | 45.80                | Fr. BRK. Hose Assy       | 1             |         |         | CHILD PART OF 4550A-SAR-0001-VN |
| 7       | 45500-VD3-0000    | 266.50               | Fr. M/C Assy             | 1             |         |         | CHILD PART OF 4550A-SAR-0001-VN |
| 8       | 4550A-SAR-0001-VN | 453.90               | Fr. Brake Ass'y          | 1             |         |         |                                 |
| 9       | 53140-VAH-0000    | 4.50                 | R. Handle Grip           | 1             |         |         |                                 |
| 10      | 53166-VAH-0000    | 3.70                 | L. Handle Grip           | 1             |         |         |                                 |
| 11      | 53167-H09-0001    | 3.70                 | Throttle Under Housing   | 1             |         |         |                                 |
| 12      | 53168-H09-0001    | 3.70                 | Throttle Upper Housing   | 1             |         |         |                                 |
| 13      | 53176-M9P-0000    | 19.50                | R.String Handle Lever    | 1             |         |         |                                 |
| 14      | 88110-SA5-9000    | 10.90                | R. Back Mirror Ass'y     | 1             |         |         |                                 |
| 15      | 88120-SA5-9000    | 10.90                | L. Back Mirror Ass'y     | 1             |         |         |                                 |
| 16      | 90122-VA1-0000    | 2.00                 | Flange Bolt 8x28         | 2             |         |         |                                 |

PRICE SHOWN IS PER PIECE. PRODUCT IMAGE PRICES ARE APPROXIMATE GUIDE ONLY.  
PRICES SHOWN ARE SUBJECT TO CHANGE WITHOUT PRIOR NOTICE.

F02

FRONT BRAKE-BACK MIRROR  
THẰNG TRƯỚC-KÍNH CHIẾU HẬU

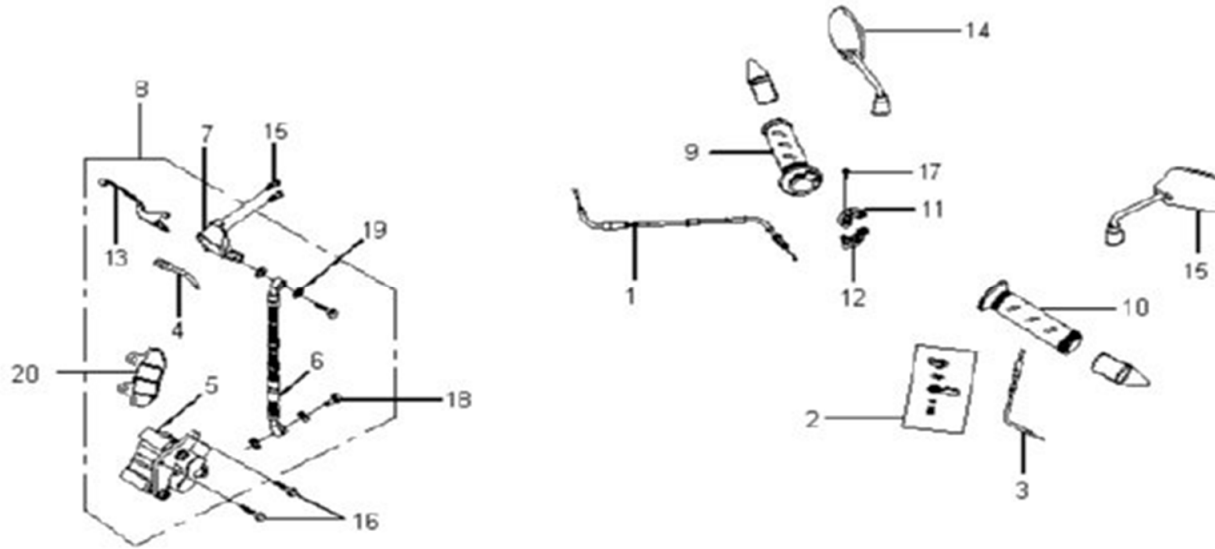

| STT No. | VMEP CODE      | SELLING PRICE RM/PCS | Tên phụ tùng<br>Description | Số lượng<br>Unit | STT No. | Mã E/C. | Ghi chú<br>Remark               |
|---------|----------------|----------------------|-----------------------------|------------------|---------|---------|---------------------------------|
| 17      | 93500-05022-00 | 0.40                 | Pan Screw 5x22              | 1                |         |         |                                 |
| 18      | 90145-MS9-6112 |                      | Oil Bolt 10x22              | 4                |         |         | CHILD PART OF 4550A-SAR-0001-VN |
| 19      | 90545-300-000E |                      | Oil Bolt Washer             | 2                |         |         | CHILD PART OF 4550A-SAR-0001-VN |
| 20      | 45105-VA1-0000 | 47.70                | Pad comp A+B                | 1                |         |         |                                 |
|         |                |                      |                             |                  |         |         |                                 |
|         |                |                      |                             |                  |         |         |                                 |
|         |                |                      |                             |                  |         |         |                                 |
|         |                |                      |                             |                  |         |         |                                 |
|         |                |                      |                             |                  |         |         |                                 |
|         |                |                      |                             |                  |         |         |                                 |
|         |                |                      |                             |                  |         |         |                                 |
|         |                |                      |                             |                  |         |         |                                 |
|         |                |                      |                             |                  |         |         |                                 |
|         |                |                      |                             |                  |         |         |                                 |

PRICE SHOWN IS PER PIECE. PRODUCT IMAGE PRICES ARE APPROXIMATE GUIDE ONLY.  
PRICES SHOWN ARE SUBJECT TO CHANDE WITHOUT PRIOR NOTICE.

F03

**HANDLE COVER**  
**NẤP TAY LÁI**

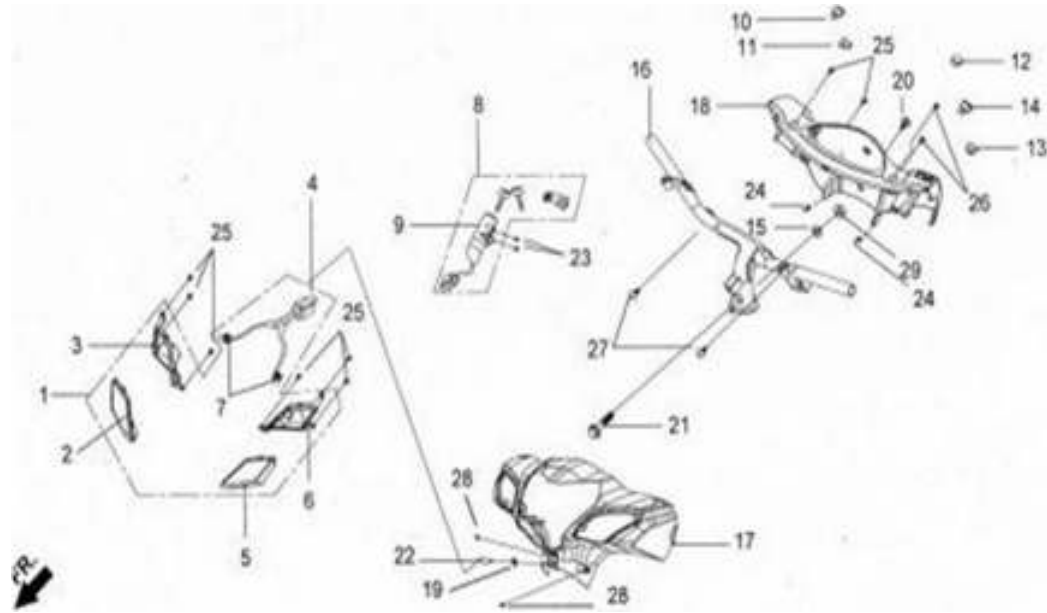

| STT No. | VMEP CODE      | SELLING PRICE RM/PCS | Tên phụ tùng<br>Description | Số lượng<br>Unit | STT No. | Mã E/C. | Ghi chú<br>Remark            |
|---------|----------------|----------------------|-----------------------------|------------------|---------|---------|------------------------------|
| 1       | 3340A-VD3-0002 | 27.70                | Fr. Winker Light Ass'y      | 1                |         |         |                              |
| 2       | 33402-VD3-0000 | 5.20                 | R. Fr. Winker Lens          | 1                |         |         |                              |
| 3       | 33411-VD3-0001 | 6.50                 | R. Fr. Winker Base          | 1                |         |         |                              |
| 4       | 33406-VD3-0000 | 5.10                 | Fr. Winker Socket Comp.     | 1                |         |         |                              |
| 5       | 33462-VD3-0000 | 5.20                 | L. Fr. Winker Lens          | 1                |         |         |                              |
| 6       | 33461-VD3-0001 | 6.50                 | L. Fr. Winker Base          | 1                |         |         |                              |
| 7       | 34905-M9Q-0000 | 2.90                 | Winker Light Bulb           | 2                |         |         |                              |
| 8       | 35010-SA5-0000 | 56.20                | Key Set                     | 1                |         |         | (PARENT PART)                |
| 9       | 35100-SA5-0000 |                      | Comp. & Switch Lock Ass'y   | 1                |         |         | CHILD PART of 35010-SA5-0000 |
| 10      | 35150-SAF-0000 | 7.50                 | Lighting Switch Unit        | 1                |         |         |                              |
| 11      | 35160-SAF-0000 | 9.30                 | Start Switch Unit           | 1                |         |         |                              |
| 12      | 35170-SAF-0000 | 9.30                 | Dimmer Switch Unit          | 1                |         |         |                              |
| 13      | 35180-SAF-0000 | 7.50                 | Horn Switch Unit            | 1                |         |         |                              |
| 14      | 35200-M9Q-0001 | 8.20                 | Winker Switch Unit          | 1                |         |         |                              |
| 15      | 47104-SB1-0000 | 1.30                 | Handle Set Collar           | 1                |         |         |                              |
| 16      | 53100-SAH-0001 | 44.40                | Handle Pipe Comp.           | 1                |         |         |                              |

PRICE SHOWN IS PER PIECE. PRODUCT IMAGE PRICES ARE APPROXIMATE GUIDE ONLY.  
PRICES SHOWN ARE SUBJECT TO CHANGE WITHOUT PRIOR NOTICE.

F03

**HANDLE COVER**  
**NẤP TAY LÁI**

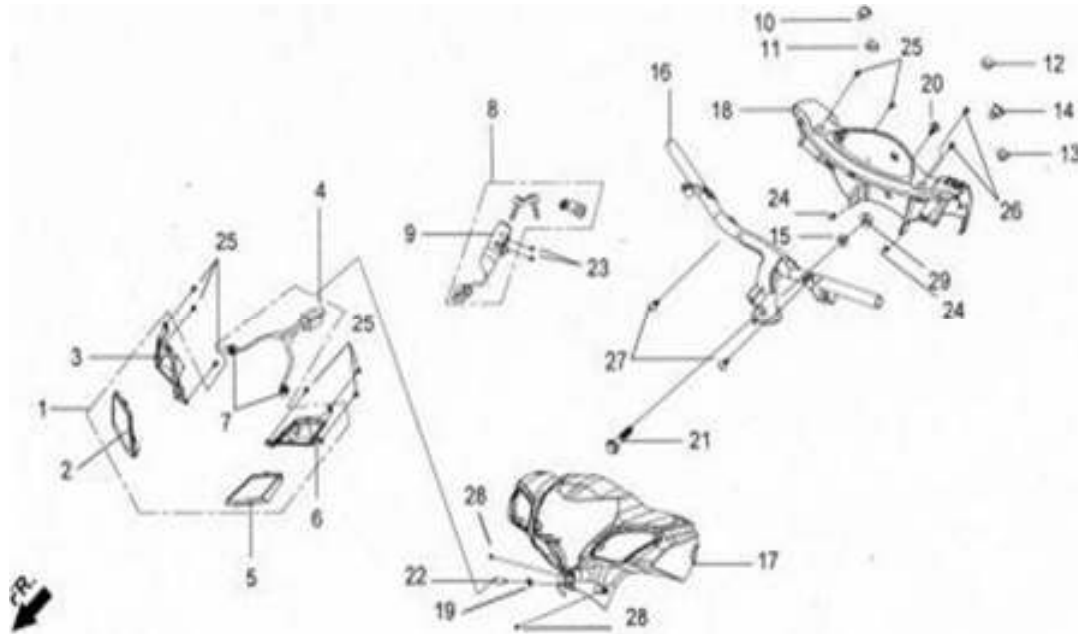

| STT No. | VMEP CODE         | SELLING PRICE RM/PCS | Tên phụ tùng<br>Description | Số lượng<br>Unit | STT No. | Mã E/C. | Ghi chú<br>Remark         |
|---------|-------------------|----------------------|-----------------------------|------------------|---------|---------|---------------------------|
| 17      | 53205-SAF-0003-KB | 22.60                | Fr. Handle Cover            | 1                |         |         | KB-BLACK, RB-RED, DH-BLUE |
| 18      | 53206-SAF-0001    | 14.50                | Rr. Handle Cover            | 1                |         |         |                           |
| 19      | 90104-VA1-0000    | 0.70                 | Fr. Fork Cover Collar       | 1                |         |         |                           |
| 20      | 90105-M40-0000    | 0.40                 | Special Screw 5x12          | 1                |         |         |                           |
| 21      | 90106-TAA-0001    | 1.60                 | Flange Bolt 10x50           | 1                |         |         |                           |
| 22      | 90115-VA3-0000    | 1.10                 | Body Cover Bolt 6x18        | 1                |         |         |                           |
| 23      | 90164-X01-0002    | 0.70                 | Flat Lock Screw 6x12        | 2                |         |         |                           |
| 24      | 90302-SA4-003B    | 0.70                 | Spring Nut 4mm              | 2                |         |         |                           |
| 25      | 93903-24220-10    | 0.60                 | Tapping Screw 4x10          | 6                |         |         |                           |
| 26      | 93903-34480-00    | 0.60                 | Tapping Screw 4x16          | 4                |         |         |                           |
| 27      | 93903-35180-00    | 0.60                 | Tapping Screw 4x16          | 2                |         |         |                           |
| 28      | 93903-44480       | 0.60                 | Tapping Screw 4x16          | 2                |         |         |                           |
| 29      | 94050-10080-00    | 0.70                 | Flange Nut 10 mm            | 1                |         |         |                           |

PRICE SHOWN IS PER PIECE. PRODUCT IMAGE PRICES ARE APPROXIMATE GUIDE ONLY.  
PRICES SHOWN ARE SUBJECT TO CHANDE WITHOUT PRIOR NOTICE.

**F04**

**FR. FENDER  
VỀ TRƯỚC**

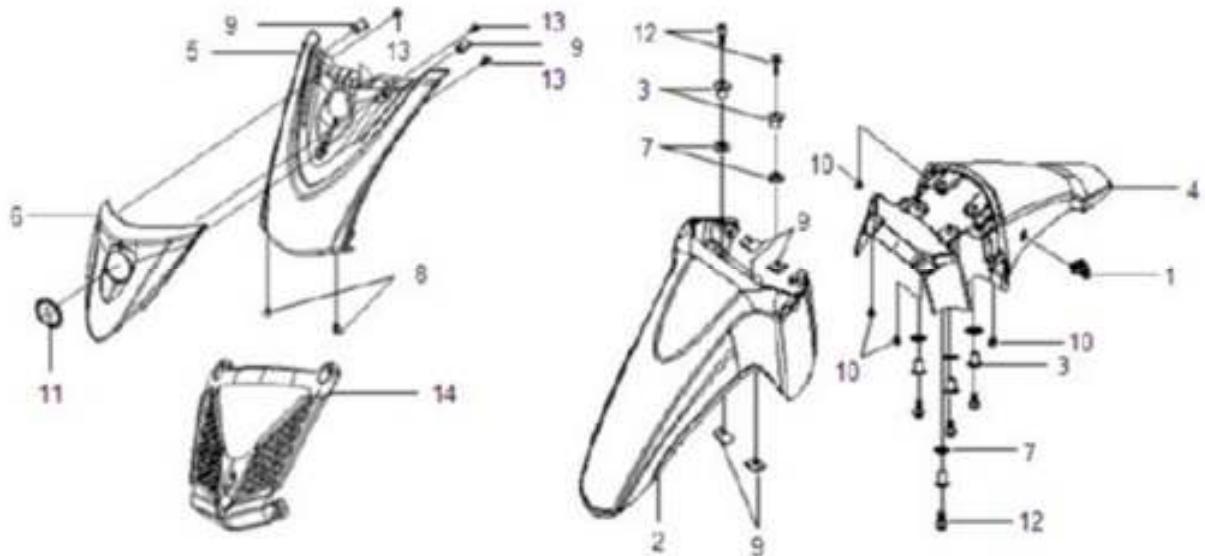

| STT No. | VMEP CODE         | SELLING PRICE RM/PCS | Tên phụ tùng Description | Số lượng Unit | STT No. | Mã E/C. | Ghi chú Remark            |
|---------|-------------------|----------------------|--------------------------|---------------|---------|---------|---------------------------|
| 1       | 45451-N02-0000    | 1.50                 | Wire Grommet             | 1             |         |         |                           |
| 2       | 61100-VD3-0001-KB | 45.30                | Fr. Fender A             | 1             |         |         | KB-BLACK, RB-RED, DH-BLUE |
| 3       | 61201-M3G-0000-A  | 0.70                 | Fr. Fender Collar        | 6             |         |         |                           |
| 4       | 61200-VD3-0003    | 32.60                | Fr. Fender B             | 1             |         |         |                           |
| 5       | 64310-SAS-0002-RB | 15.00                | Fr. Top Cover            | 1             |         |         | RB-RED, WF-WHITE          |
| 6       | 64312-SAU-0000-KB | 16.50                | Fr. Top Cover Emblem     | 1             |         |         | KB-BLACK, RB-RED, DH-BLUE |
| 7       | 77226-M3F-0000    | 0.40                 | Damping Rubber           | 6             |         |         |                           |
| 8       | 93903-44480       | 0.60                 | Tapping Screw 4x16       | 2             |         |         |                           |
| 9       | 90302-SA4-003B    | 0.70                 | Spring Nut 4Mm           | 6             |         |         |                           |
| 10      | 93903-24280       | 0.60                 | Tapping Screw 4x10       | 4             |         |         |                           |
| 11      | 87123-H85-0000    | 7.50                 | S Logo (40 Poly)         | 1             |         |         |                           |
| 12      | 95801-06020-00    | 0.70                 | Flange Bolt 6x20         | 6             |         |         |                           |
| 13      | 93903-34320-00    | 0.60                 | Tapping Screw 4x12       | 3             |         |         |                           |
| 14      | 64311-SAS-0001    | 9.90                 | Fr. Top Cover Grid       | 1             |         |         |                           |

PRICE SHOWN IS PER PIECE. PRODUCT IMAGE PRICES ARE APPROXIMATE GUIDE ONLY.  
PRICES SHOWN ARE SUBJECT TO CHANDE WITHOUT PRIOR NOTICE.

F05

**FRONT FORK SET**  
**BỘ PHỤỘC TRƯỚC**

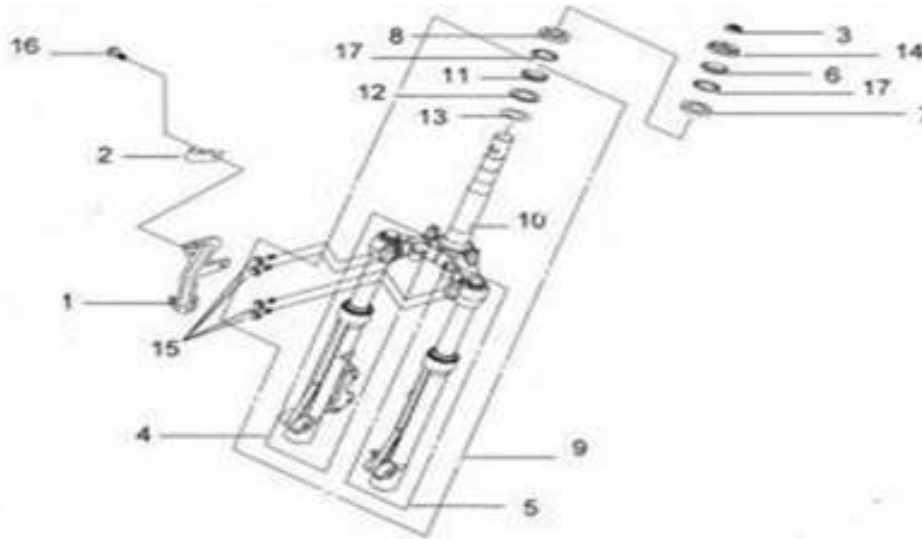

| STT No. | VMEP CODE         | SELLING PRICE RM/PCS | Tên phụ tùng<br>Description | Số lượng<br>Unit | STT No. | Mã E/C. | Ghi chú<br>Remark           |
|---------|-------------------|----------------------|-----------------------------|------------------|---------|---------|-----------------------------|
| 1       | 45156-VD3-0003    | 3.50                 | Brake Hose Clamp            | 1                |         |         |                             |
| 2       | 45157-VA1-0001    | 2.90                 | Brake Hose Clamp B          | 1                |         |         |                             |
| 3       | 51718-SB1-0000    | 5.70                 | Steering Stem Lock Nut      | 1                |         |         |                             |
| 4       | 51400-VAG-0000    | 121.10               | R. Fr. Cushion Ass'y        | 1                |         |         | CHILD PART OF 5320A-SAR-000 |
| 5       | 51500-VAG-0000    | 121.10               | L. Fr. Cushion Ass'y        | 1                |         |         | CHILD PART OF 5320A-SAR-000 |
| 4,5-1   | 51401-VD3-0000    | 8.30                 | SPRING                      | 1                |         |         |                             |
| 4,5-2   | 51410-VD3-0000    | 60.50                | FORK PIPE COMP              | 1                |         |         |                             |
| 4,5-3   | 51412-VD3-0000    | 2.80                 | REBOUND SPRING              | 1                |         |         |                             |
| 4,5-4   | 51421-VAG-0000    | 72.70                | BOTTOM CASE - RH            | 1                |         |         |                             |
| 4,5-5   | 51432-X15-0000    | 3.80                 | OIL LOCK PIECE              | 1                |         |         |                             |
| 4,5-6   | 51437-X15-0000    | 1.00                 | PISTON RING                 | 1                |         |         |                             |
| 4,5-7   | 51440-VD3-0000    | 8.70                 | PIPE SEAT                   | 1                |         |         |                             |
| 4,5-8   | 51493-M36-0000    | 0.40                 | O-RING                      | 1                |         |         |                             |
| 4,5-9   | 51521-VAG-0000    | 72.70                | BOTTOM CASE - LH            | 1                |         |         |                             |
| 4,5-10  | 90103-VD3-0000    | 13.80                | FORK BOLT                   | 4                |         |         |                             |
| 4,5-11  | 90110-VD3-0000    | 2.80                 | DUST SEAL                   | 1                |         |         |                             |
| 4,5-12  | 90116-383-7211-M1 | 1.00                 | SCOKET BOLT 8MM             | 50               |         |         |                             |

PRICE SHOWN IS PER PIECE. PRODUCT IMAGE PRICES ARE APPROXIMATE GUIDE ONLY.  
PRICES SHOWN ARE SUBJECT TO CHANDE WITHOUT PRIOR NOTICE.



F05

**FRONT FORK SET**  
**BỘ PHỤỘC TRƯỚC**

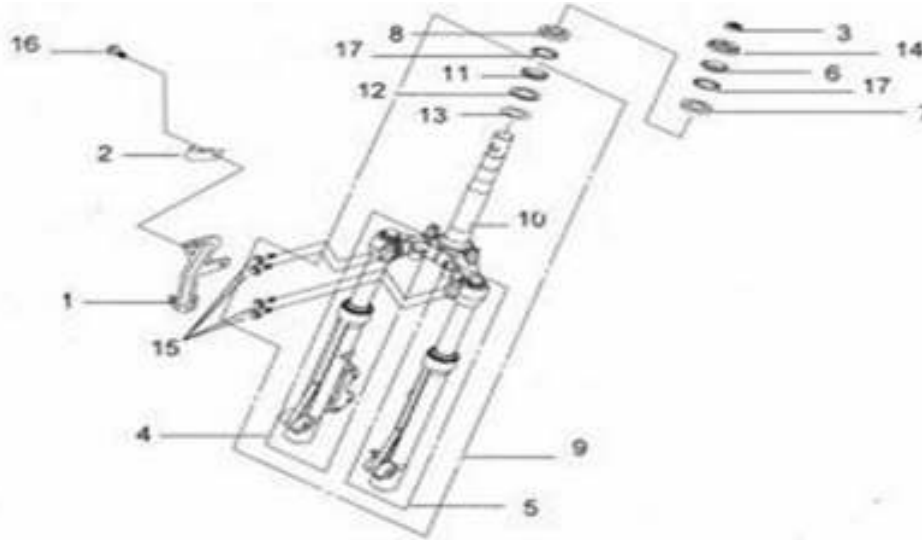

| STT No. | VMEP CODE      | SELLING PRICE RM/PCS | Tên phụ tùng<br>Description    | Số lượng<br>Unit | STT No. | Mã E/C. | Ghi chú<br>Remark                             |
|---------|----------------|----------------------|--------------------------------|------------------|---------|---------|---|
| 4,5-13  | 90544-S08-0000 | 2.60                 | PACKING 8MM                    | 1                |         |         |   |
| 4,5-14  | 90601-X15-0000 | 0.70                 | OIL SEAL STOPPER RING          | 1                |         |         |   |
| 4,5-15  | 91255-VD3-0000 | 7.20                 | OIL SEAL                       | 1                |         |         |   |
| 6       | 51711-SB1-0000 | 5.70                 | Steering Top Cone Race         | 1                |         |         |   |
| 7       | 51712-SB1-0000 | 5.70                 | Steering Top Ball Race         | 1                |         |         |   |
| 8       | 51713-SB1-0000 | 5.70                 | Steering Bottom Ball Race      | 1                |         |         |   |
| 9       | 5320A-SAR-000  |                      | Fr. Fork Set                   | 1                |         |         | Parent part, please order full set child part |
| 10      | 5320B-SA6-0000 | 123.80               | STRG. STEM COMP. SET           | 1                |         |         | CHILD PART OF 5320A-SAR-000                   |
| 11      | 53212-VA3-0000 | 11.20                | Steering Bottom Cone Race      | 1                |         |         |   |
| 12      | 53214-X04-0000 | 2.00                 | Steering Head Dust Seal        | 1                |         |         |   |
| 13      | 53215-X04-0001 | 0.70                 | Steering Head Dust Seal Washer | 1                |         |         |   |
| 14      | 53220-VA3-0001 | 8.20                 | Steering Head Top Thread       | 1                |         |         |   |
| 15      | 90105-VA1-0001 | 2.00                 | Flange Bolt 10x42.5            | 4                |         |         | CHILD PART OF 5320A-SAR-000                   |
| 16      | 96001-06010-08 | 0.80                 | Sh. Flange Bolt 6x10           | 1                |         |         |   |
| 17      | 9621A-06000-00 | 32.00                | Steel Ball 6                   | 50               |         |         | RM 32 PER SET ( 100PCS )                      |
|         |                |                      |                                |                  |         |         |   |
|         |                |                      |                                |                  |         |         |   |

PRICE SHOWN IS PER PIECE. PRODUCT IMAGE PRICES ARE APPROXIMATE GUIDE ONLY.  
PRICES SHOWN ARE SUBJECT TO CHANGE WITHOUT PRIOR NOTICE.

**F06**

**FRONT COVER-MAIN PIPE UP COVER**  
**BỤNG TRƯỚC-YẾM XE**

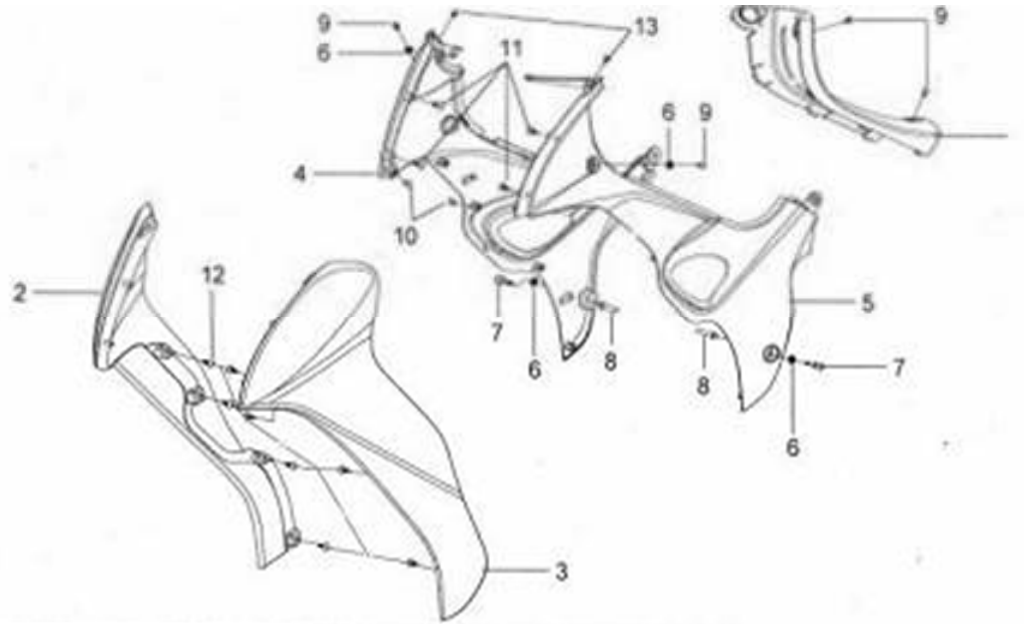

| STT No. | VMEP CODE         | SELLING PRICE RM/PCS | Tên phụ tùng<br>Description | Số lượng<br>Unit | STT No. | Mã E/C. | Ghi chú<br>Remark         |
|---------|-------------------|----------------------|-----------------------------|------------------|---------|---------|---------------------------|
| 1       | 64100-SA5-0000    | 13.60                | Main Pipe Up Cover          | 1                |         |         |                           |
| 2       | 64301-SAF-0000-KB | 42.00                | R. Front Cover              | 1                |         |         | KB-BLACK, RB-RED, DH-BLUE |
| 3       | 64302-SAF-0000-KB | 42.00                | L. Front Cover              | 1                |         |         | KB-BLACK, RB-RED, DH-BLUE |
| 4       | 64303-SA5-0002-RB | 18.00                | R. Main Pipe Cover          | 1                |         |         | RB-RED, WH- WHITE         |
| 5       | 64304-SA5-0002-RB | 18.00                | L. Main Pipe Cover          | 1                |         |         | RB-RED, WH- WHITE         |
| 6       | 64304-X01-0000    | 0.70                 | Fr. Cover Rubber            | 4                |         |         |                           |
| 7       | 64305-SA5-A000    | 1.10                 | Fr. Cover Screw             | 2                |         |         |                           |
| 8       | 64307-SA5-A000    | 1.10                 | Fr. Cover Collar            | 2                |         |         |                           |
| 9       | 90110-GZ0-000A    | 0.70                 | Special Screw 6x14          | 4                |         |         |                           |
| 10      | 90302-SA4-003B    | 0.70                 | Spring Nut 4 mm             | 2                |         |         |                           |
| 11      | 93903-34320-00    | 0.60                 | Tapping Screw 4x12          | 4                |         |         |                           |
| 12      | 93903-35220-00    | 0.60                 | Tapping Screw 5x12          | 8                |         |         |                           |
| 13      | 93903-44480       | 0.60                 | Tapping Screw 4x16          | 2                |         |         |                           |

PRICE SHOWN IS PER PIECE. PRODUCT IMAGE PRICES ARE APPROXIMATE GUIDE ONLY.  
 PRICES SHOWN ARE SUBJECT TO CHANDE WITHOUT PRIOR NOTICE.

F07

**FRONT WHEEL-BRAKE DISK**  
**BÁNH TRƯỚC-THẮNG DĨA**

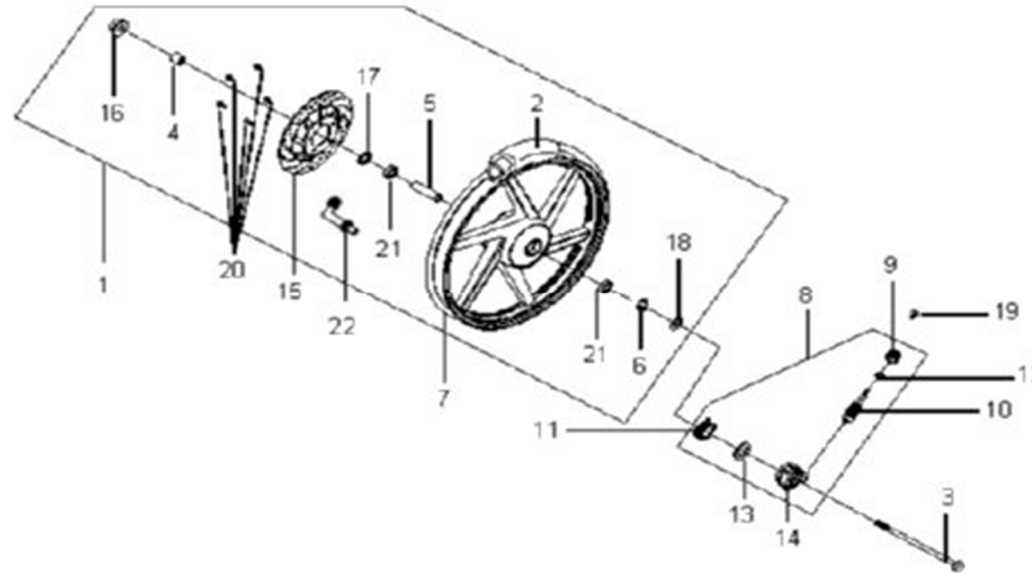

| STT No. | VMEP CODE            | SELLING PRICE RM/PCS | Tên phụ tùng<br>Description | Số lượng<br>Unit | STT No. | Mã E/C. | Ghi chú<br>Remark                           |
|---------|----------------------|----------------------|-----------------------------|------------------|---------|---------|---|
| 1       | 44600-SAH-010        |                      | Fr. Wheel Ass'y             | 1                |         |         | Parent part, pls order full set child part. |
| 2       | 44710-SAH-0000       | 84.70                | Fr. Tubeless Tire Ass'Y     | 1                |         |         | CHILD PART OF 44600-SAH-010                 |
| 3       | 44301-VA5-0001       | 7.50                 | Fr. Wheel Axle              | 1                |         |         |   |
| 4       | 44311-VVB-0000       | 2.60                 | Fr. Wheel Side Collar       | 1                |         |         |   |
| 5       | 44620-VA1-0000       | 3.00                 | Fr. Axle Distance Collar    | 1                |         |         | CHILD PART OF 44600-SAH-010                 |
| 6       | 44680-VA1-000        | 2.10                 | Gear Box Retainer           | 1                |         |         | CHILD PART OF 44600-SAH-010                 |
| 7       | 44701-SAH-0001-VN    | 244.30               | Fr. Wheel Cast              | 1                |         |         | CHILD PART OF 44600-SAH-010                 |
| 8       | 44800-VA9-0000       | 58.70                | Gear Box Ass'y              | 1                |         |         | PARENT PART                                 |
| 9       | 44803-VA1-0000-M1(X) |                      | Pinion Bush                 | 1                |         |         | CHILD PART OF 44800-VA9-0000                |
| 10      | 44805-VA1-0000-M1(X) |                      | Speedometer Pinion          | 1                |         |         | CHILD PART OF 44800-VA9-0000                |
| 11      | 44806-VA1-0001-M1(X) |                      | Speedometer Gear            | 1                |         |         | CHILD PART OF 44800-VA9-0000                |
| 12      | 44807-VA1-000        |                      | Gear Box Pinion Washer      | 1                |         |         | CHILD PART OF 44800-VA9-0000                |
| 13      | 44809-VA1-0000-M1(X) |                      | Speedometer Gear Washer     | 1                |         |         | CHILD PART OF 44800-VA9-0000                |
| 14      | 44820-VA9-000        |                      | Speedometer Gear Box Comp.  | 1                |         |         | CHILD PART OF 44800-VA9-0000                |
| 15      | 45121-VA1-0000       | 121.10               | Fr. Brake Disk              | 1                |         |         | CHILD PART OF 44600-SAH-010                 |
| 16      | 54207-SB1-0000       | 1.60                 | Fr. Axle Nut                | 1                |         |         |   |

PRICE SHOWN IS PER PIECE. PRODUCT IMAGE PRICES ARE APPROXIMATE GUIDE ONLY.  
PRICES SHOWN ARE SUBJECT TO CHANGE WITHOUT PRIOR NOTICE.

F07

**FRONT WHEEL-BRAKE DISK**  
**BÁNH TRƯỚC-THẮNG ĐĨA**

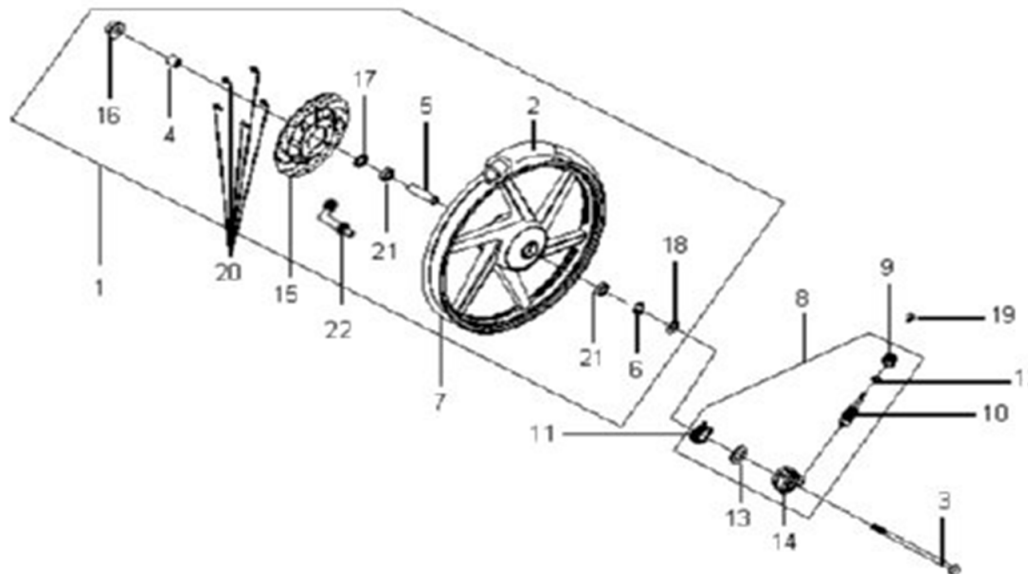

| STT No. | VMEP CODE      | SELLING PRICE RM/PCS | Tên phụ tùng<br>Description   | Số lượng<br>Unit | STT No. | Mã E/C. | Ghi chú<br>Remark           |
|---------|----------------|----------------------|-------------------------------|------------------|---------|---------|-----------------------------|
| 17      | 91252-030-003A | 1.60                 | Oil Seal 23x37x7              | 1                |         |         | CHILD PART OF 44600-SAH-010 |
| 18      | 91258-410-0131 | 2.20                 | Dust Seal 40x50x5             | 1                |         |         | CHILD PART OF 44600-SAH-010 |
| 19      | 93891-05022-07 | 0.70                 | Washer Screw 5x22             | 1                |         |         |                             |
| 20      | 95801-VD7-0000 | 0.80                 | Flange Bolt 6x22              | 5                |         |         | CHILD PART OF 44600-SAH-010 |
| 21      | 96140-63010-10 | 10.00                | Radial Ball Bearing 6301 (UU) | 2                |         |         | CHILD PART OF 44600-SAH-010 |
| 22      | 42753-VVA-0000 | 11.40                | Rim Valve                     | 1                |         |         | CHILD PART OF 44600-SAH-010 |
|         |                |                      |                               |                  |         |         |                             |
|         |                |                      |                               |                  |         |         |                             |
|         |                |                      |                               |                  |         |         |                             |
|         |                |                      |                               |                  |         |         |                             |
|         |                |                      |                               |                  |         |         |                             |
|         |                |                      |                               |                  |         |         |                             |
|         |                |                      |                               |                  |         |         |                             |
|         |                |                      |                               |                  |         |         |                             |
|         |                |                      |                               |                  |         |         |                             |

PRICE SHOWN IS PER PIECE. PRODUCT IMAGE PRICES ARE APPROXIMATE GUIDE ONLY.  
 PRICES SHOWN ARE SUBJECT TO CHANDE WITHOUT PRIOR NOTICE.

F08

**REAR BRAKE PANEL**  
**MÁ ĐÙM SAU**

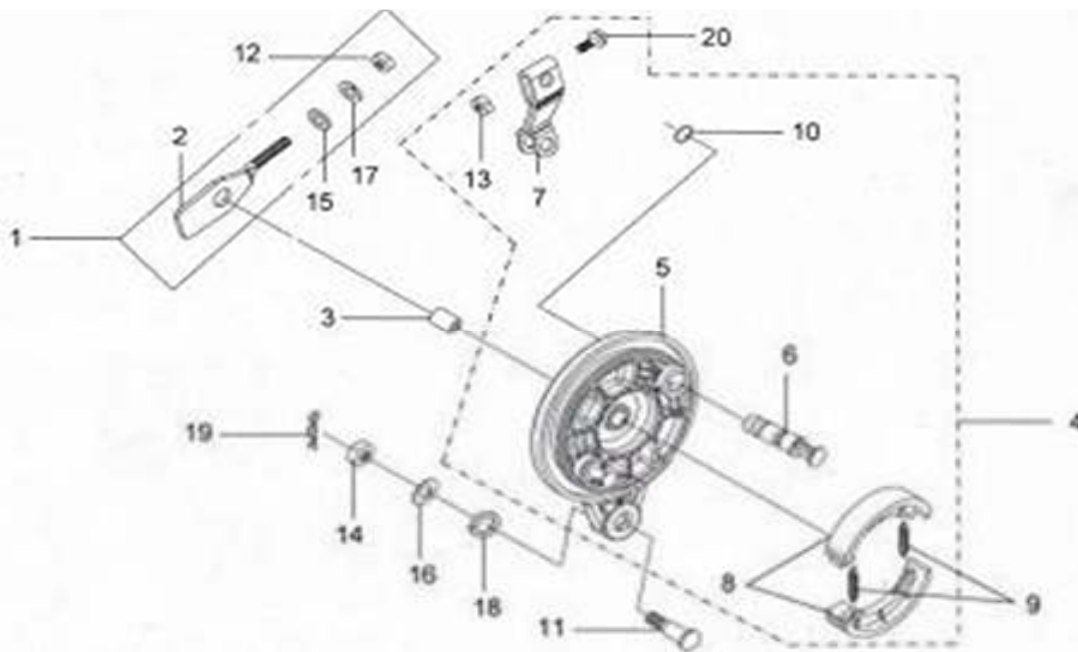

| STT No. | VMEP CODE         | SELLING PRICE RM/PCS | Tên phụ tùng<br>Description   | Số lượng<br>Unit | STT No. | Mã E/C. | Ghi chú<br>Remark                              |
|---------|-------------------|----------------------|-------------------------------|------------------|---------|---------|--|
| 1       | 4054A-VAD-0000    | 4.90                 | R. Drive Chain Adjuster Ass'y | 1                |         |         |  |
| 2       | 40543-VAD-000     |                      | R. Drive Chain Adjuster       | 1                |         |         |  |
| 3       | 42313-SAH-0000    | 3.50                 | Rr. Brake Panel Side Collar   | 1                |         |         |  |
| 4       | 43000-VDA-0000(X) |                      | Rr. Brake Panel Ass'y         | 1                |         |         | PARENT PART (Please order full set child part) |
| 5       | 43100-X01-0202-SE | 48.70                | Rr. Brake Panel               | 1                |         |         | Child part of 43000-VDA-0000                   |
| 6       | 43141-A02-0103    | 4.10                 | Brake Cam                     | 1                |         |         | Child part of 43000-VDA-0000                   |
| 7       | 43410-M3B-0001    | 6.50                 | Rr. Brake Arm                 | 1                |         |         | Child part of 43000-VDA-0000                   |
| 8       | 4512B-ADA-0000    | 13.70                | Brake Shoe Comp.              | 2                |         |         | Child part of 43000-VDA-0000                   |
| 9       | 45133-A10-0000    | 0.80                 | Brake Shoe Spring             | 2                |         |         | Child part of 43000-VDA-0000                   |
| 10      | 45134-M9Q-0000    | 1.20                 | Brake Cam Dust Seal           | 1                |         |         |  |
| 11      | 90127-M8Q-0000    | 0.70                 | Rr. Brake Torque Bolt         | 1                |         |         |  |
| 12      | 94001-06000-00    | 0.60                 | Hex Nut 6 mm                  | 1                |         |         |  |
| 13      | 94050-06000-00    | 0.70                 | Flange Nut 6 mm               | 1                |         |         | Child part of 43000-VDA-0000                   |
| 14      | 94050-08000       | 0.70                 | Flange Nut 8 mm               | 1                |         |         |  |
| 15      | 94101-06000       | 0.40                 | Plain Washer 6 mm             | 1                |         |         |  |
| 16      | 94101-08000       | 0.50                 | Plain Washer 8 mm             | 1                |         |         |  |

PRICE SHOWN IS PER PIECE. PRODUCT IMAGE PRICES ARE APPROXIMATE GUIDE ONLY.  
PRICES SHOWN ARE SUBJECT TO CHANDE WITHOUT PRIOR NOTICE.

F08

**REAR BRAKE PANEL**  
**MÁ ĐÙM SAU**

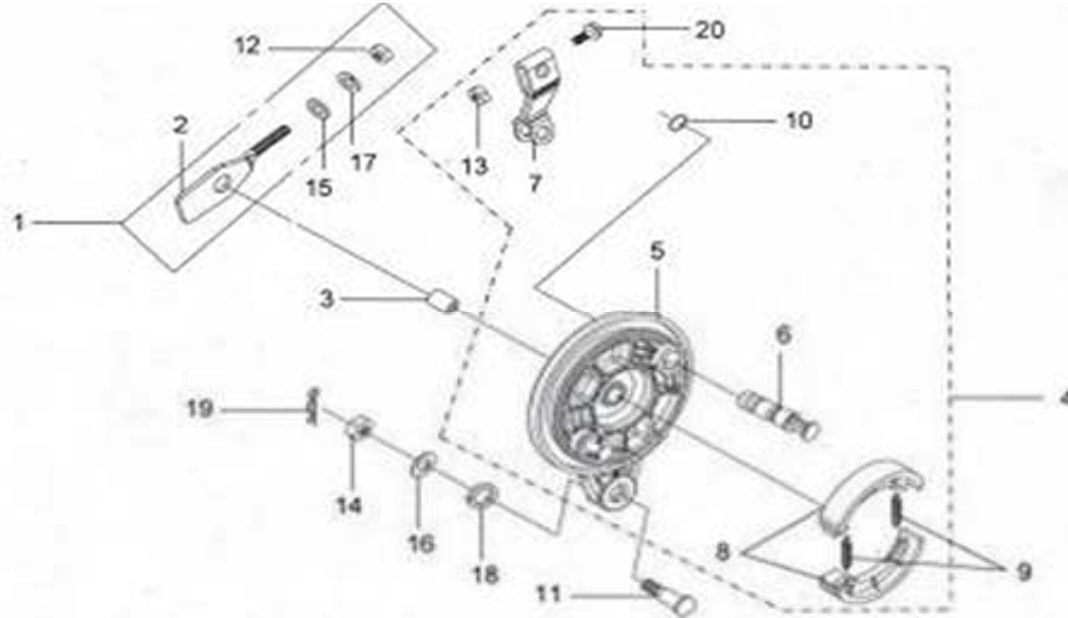

| STT No. | VMEP CODE      | SELLING PRICE RM/PCS | Tên phụ tùng<br>Description | Số lượng<br>Unit | STT No. | Mã E/C. | Ghi chú<br>Remark            |
|---------|----------------|----------------------|-----------------------------|------------------|---------|---------|------------------------------|
| 17      | 94111-06000-00 | 0.40                 | Spring Washer 6 mm          | 1                |         |         |                              |
| 18      | 94111-10000-00 | 0.70                 | Spring Washer 10 mm         | 1                |         |         |                              |
| 19      | 94251-08400    | 0.80                 | Lock Pin 8 mm               | 1                |         |         |                              |
| 20      | 95701-06032-00 | 0.70                 | Flange Bolt 6x32 mm         | 1                |         |         | Child part of 43000-VDA-0000 |
|         |                |                      |                             |                  |         |         |                              |
|         |                |                      |                             |                  |         |         |                              |
|         |                |                      |                             |                  |         |         |                              |
|         |                |                      |                             |                  |         |         |                              |
|         |                |                      |                             |                  |         |         |                              |
|         |                |                      |                             |                  |         |         |                              |
|         |                |                      |                             |                  |         |         |                              |
|         |                |                      |                             |                  |         |         |                              |
|         |                |                      |                             |                  |         |         |                              |
|         |                |                      |                             |                  |         |         |                              |

PRICE SHOWN IS PER PIECE. PRODUCT IMAGE PRICES ARE APPROXIMATE GUIDE ONLY.  
PRICES SHOWN ARE SUBJECT TO CHANDE WITHOUT PRIOR NOTICE.

F09

**REAR WHEEL  
BÁNH SAU**

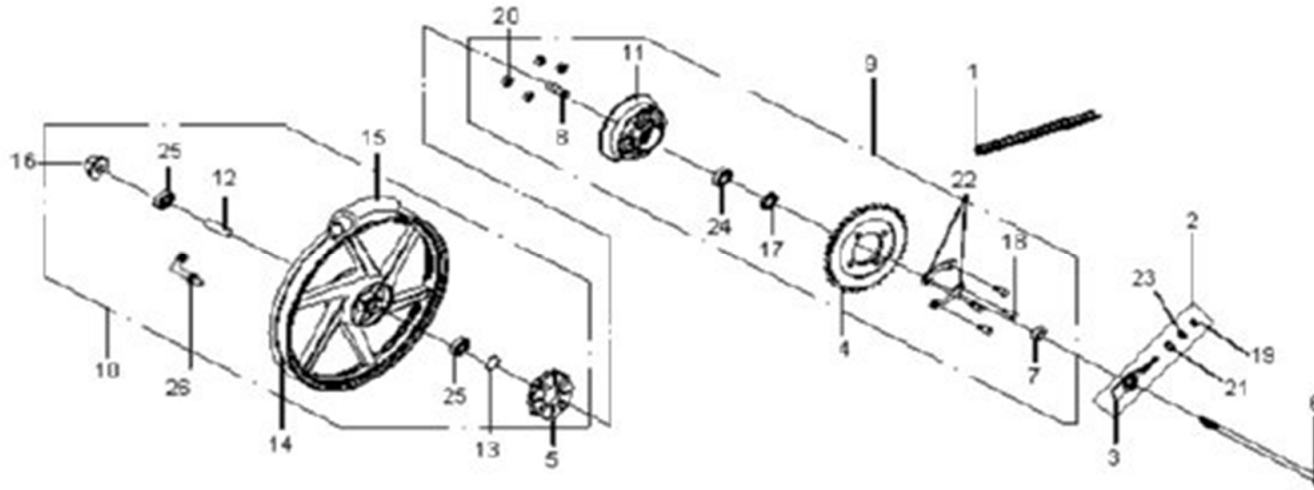

| STT No. | VMEP CODE         | SELLING PRICE RM/PCS | Tên phụ tùng Description      | Số lượng Unit | STT No. | Mã E/C. | Ghi chú Remark                                |
|---------|-------------------|----------------------|-------------------------------|---------------|---------|---------|---|
| 1       | 1CS 428H X 102L   | 23.20                | Drive Chain (102L)            | 1             |         |         |   |
| 2       | 4054A-VAD-0000    | 4.90                 | R. Drive Chain Adjuster Ass'y | 1             |         |         |   |
| 3       | 40543-VAD-000     |                      | R. Drive Chain Adjuster       | 1             |         |         |   |
| 4       | 41201-SAB-0000    | 25.00                | Final Driven Sprocket (38T)   | 1             |         |         | Child part of 4260A-SAE-0002                  |
| 5       | 41241-VDA-0001    | 1.60                 | Rr. Wheel Damper              | 4             |         |         |   |
| 6       | 42301-SAE-0000    | 11.50                | Rr. Wheel Axle                | 1             |         |         |   |
| 7       | 42304-SAE-0000    | 3.00                 | Final Driven Side Collar      | 1             |         |         | Child part of 4260A-SAE-0002                  |
| 8       | 42305-SAE-0002    | 2.40                 | Final Driven Inner Collar     | 1             |         |         | Child part of 4260A-SAE-0002                  |
| 9       | 4260A-SAE-0002(X) |                      | Final Driven Ass'y            | 1             |         |         | Parent part, please order full set child part |
| 10      | 4260B-SAH-010     |                      | Rr. Wheel Sub Ass'y           | 1             |         |         |   |
| 11      | 42610-VA3-0000    | 22.80                | Final Driven Flange           | 1             |         |         |   |
| 12      | 42620-X01-0000    | 3.00                 | Rr. Axle Distance Collar      | 1             |         |         |   |
| 13      | 42653-001-0041    | 1.10                 | O-Ring 40.5x3                 | 1             |         |         |   |
| 14      | 42701-SAH-0001-VN | 258.70               | Rr. Wheel Cast                | 1             |         |         |   |
| 15      | 42710-SAH-0000    | 101.00               | Rr. Tire Ass'y                | 1             |         |         |   |
| 16      | 90306-SB1-0000    | 2.80                 | Rr. Axle Nut                  | 1             |         |         |   |

PRICE SHOWN IS PER PIECE. PRODUCT IMAGE PRICES ARE APPROXIMATE GUIDE ONLY.  
PRICES SHOWN ARE SUBJECT TO CHANGE WITHOUT PRIOR NOTICE.

F09

**REAR WHEEL**  
**BÁNH SAU**

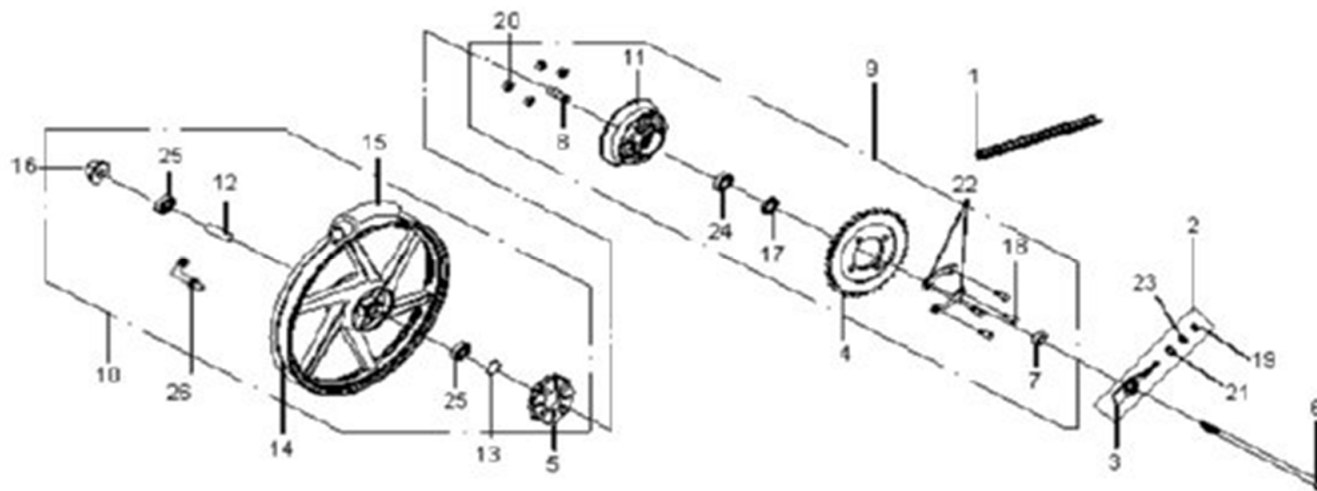

| STT No. | VMEP CODE      | SELLING PRICE RM/PCS | Tên phụ tùng Description   | Số lượng Unit | STT No. | Mã E/C. | Ghi chú Remark               |
|---------|----------------|----------------------|----------------------------|---------------|---------|---------|------------------------------|
| 17      | 90753-029-003A | 2.40                 | Oil Seal 27x40x6           | 1             |         |         | Child part of 4260A-SAE-0002 |
| 18      | 92101-08032-0A | 0.70                 | Hex Bolt 8x32              | 4             |         |         | Child part of 4260A-SAE-0002 |
| 19      | 94001-06000-00 | 0.60                 | Hex Nut 6 mm               | 1             |         |         |                              |
| 20      | 94030-08000-00 | 1.10                 | Hex Nut 8 mm               | 4             |         |         | Child part of 4260A-SAE-0002 |
| 21      | 94101-06000    | 0.40                 | Plain Washer 6 mm          | 1             |         |         |                              |
| 22      | 94108-11000-00 | 0.70                 | Tongued Washer             | 2             |         |         | Child part of 4260A-SAE-0002 |
| 23      | 94111-06000-00 | 0.40                 | Spring Washer 6 mm         | 1             |         |         |                              |
| 24      | 96100-62030-00 | 9.70                 | Radial Ball Bearing 6203Z  | 1             |         |         | Child part of 4260A-SAE-0002 |
| 25      | 96140-63010-10 | 10.00                | Radial Ball Bearing 6301UU | 2             |         |         |                              |
| 26      | 42753-VVA-0000 | 11.40                | Rim Valve                  | 1             |         |         |                              |
|         |                |                      |                            |               |         |         |                              |
|         |                |                      |                            |               |         |         |                              |
|         |                |                      |                            |               |         |         |                              |
|         |                |                      |                            |               |         |         |                              |

PRICE SHOWN IS PER PIECE. PRODUCT IMAGE PRICES ARE APPROXIMATE GUIDE ONLY.  
PRICES SHOWN ARE SUBJECT TO CHANGE WITHOUT PRIOR NOTICE.



**F10**

**DOUBLE SEAT  
YÊN XE**

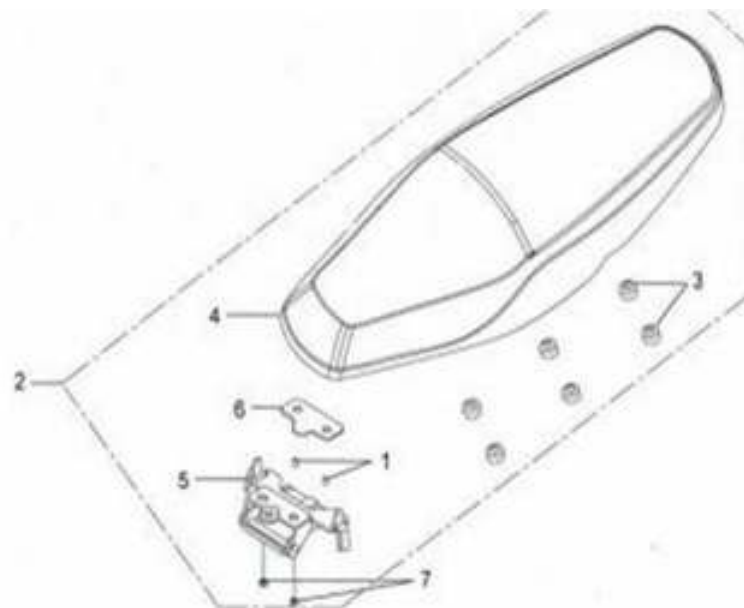

| STT No. | VMEP CODE         | SELLING PRICE RM/PCS | Tên phụ tùng Description | Số lượng Unit | STT No. | Mã E/C. | Ghi chú Remark               |
|---------|-------------------|----------------------|--------------------------|---------------|---------|---------|------------------------------|
| 1       | 12396-SAE-0000    | 0.70                 | Seat Hinge Collar        | 2             |         |         | CHILD PART OF 77200-SAH-0003 |
| 2       | 77200-SAH-0003    | 77.60                | Double Seat Ass'y        | 1             |         |         |                              |
| 3       | 77206-M51-0000    | 1.10                 | Seat Stopper Rubber      | 6             |         |         | CHILD PART OF 77200-SAH-0003 |
| 4       | 77210-SAH-0003(X) |                      | Double Seat Comp.        | 1             |         |         | CHILD PART OF 77200-SAH-0003 |
| 5       | 77211-SAE-0000    | 5.00                 | Seat Hinge Comp.         | 1             |         |         | CHILD PART OF 77200-SAH-0003 |
| 6       | 77212-SAE-0000    | 1.00                 | Seat Hinge Rubber        | 1             |         |         | CHILD PART OF 77200-SAH-0003 |
| 7       | 94050-06080       | 1.00                 | Flange Nut 6 mm          | 2             |         |         |                              |
|         |                   |                      |                          |               |         |         |                              |
|         |                   |                      |                          |               |         |         |                              |
|         |                   |                      |                          |               |         |         |                              |
|         |                   |                      |                          |               |         |         |                              |
|         |                   |                      |                          |               |         |         |                              |
|         |                   |                      |                          |               |         |         |                              |

PRICE SHOWN IS PER PIECE. PRODUCT IMAGE PRICES ARE APPROXIMATE GUIDE ONLY.  
PRICES SHOWN ARE SUBJECT TO CHANGE WITHOUT PRIOR NOTICE.

F11

FUEL TANK  
THÙNG XĂNG

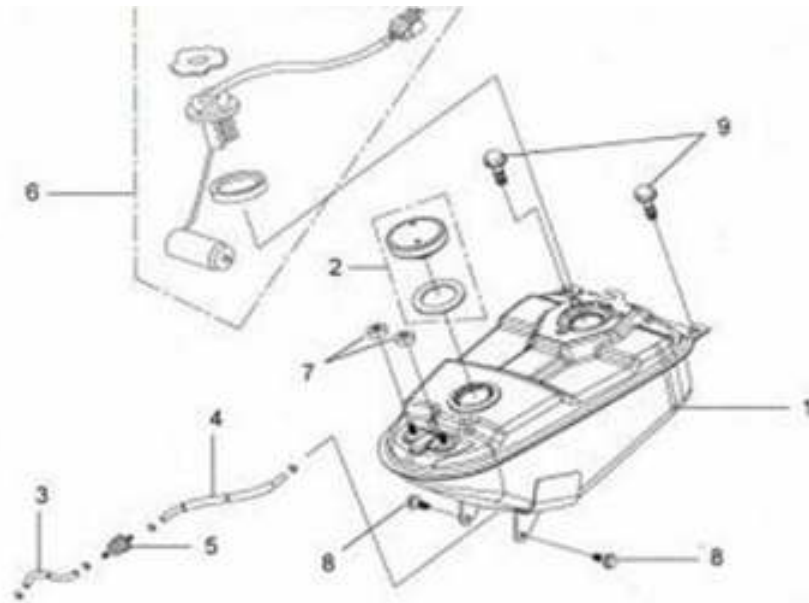

| STT No. | VMEP CODE      | SELLING PRICE RM/PCS | Tên phụ tùng Description | Số lượng Unit | STT No. | Mã E/C. | Ghi chú Remark |
|---------|----------------|----------------------|--------------------------|---------------|---------|---------|----------------|
| 1       | 17500-SA5-0010 | 56.20                | Fuel Tank Comp.          | 1             |         |         |                |
| 2       | 17620-VA3-0000 | 18.70                | Fuel Filler Cap assy.    | 1             |         |         |                |
| 3       | 16802-SA5-0002 | 1.80                 | Fuel Tube 5.3x50         | 1             |         |         |                |
| 4       | 16820-SB1-0000 | 6.70                 | Fuel Tube 5.3            | 1             |         |         |                |
| 5       | 16920-SB1-0000 | 4.10                 | Fuel Strainer Comp.      | 1             |         |         |                |
| 6       | 37800-SA1-0000 | 13.00                | Fuel Unit Ass'y          | 1             |         |         |                |
| 7       | 94050-06080    | 1.00                 | Flange Nut 6 mm          | 2             |         |         |                |
| 8       | 95801-06012-00 | 0.40                 | Flange Bolt 6x12         | 2             |         |         |                |
| 9       | 95801-08016-08 | 0.80                 | Flange Bolt 8x16         | 2             |         |         |                |
|         |                |                      |                          |               |         |         |                |
|         |                |                      |                          |               |         |         |                |
|         |                |                      |                          |               |         |         |                |
|         |                |                      |                          |               |         |         |                |

PRICE SHOWN IS PER PIECE. PRODUCT IMAGE PRICES ARE APPROXIMATE GUIDE ONLY.  
PRICES SHOWN ARE SUBJECT TO CHANGE WITHOUT PRIOR NOTICE.

F12

**AIR CLEANER**  
**BỘ LỌC GIÓ**

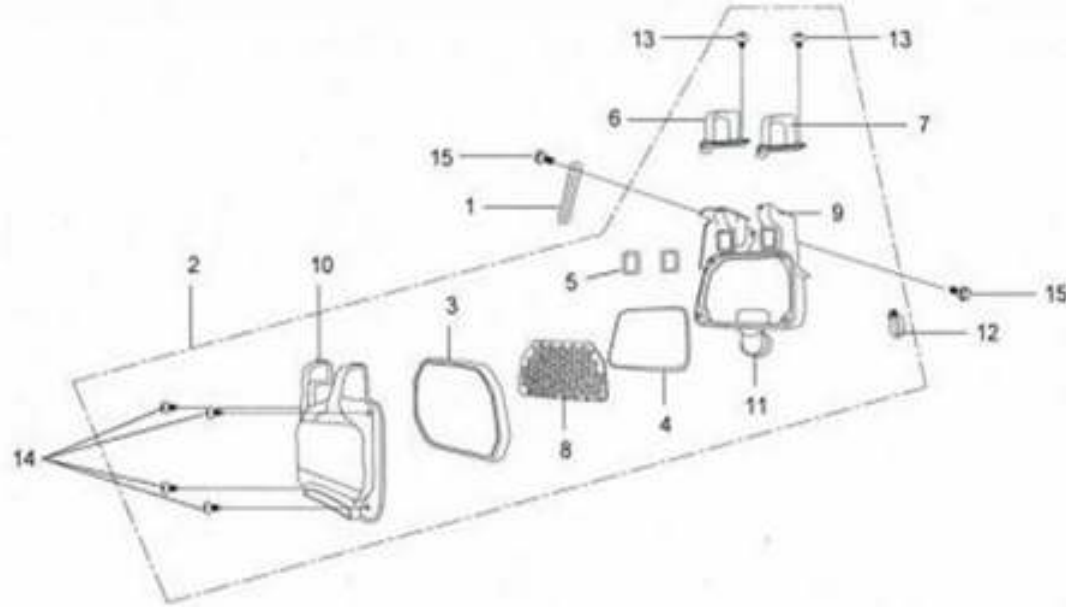

| STT No. | VMEP CODE         | SELLING PRICE RM/PCS | Tên phụ tùng Description           | Số lượng Unit | STT No. | Mã E/C. | Ghi chú Remark               |
|---------|-------------------|----------------------|------------------------------------|---------------|---------|---------|------------------------------|
| 1       | 12342-X01-0000    | 1.10                 | Clamp                              | 1             |         |         |                              |
| 2       | 17200-VA2-0001    | 39.10                | Air Cleaner Ass'y                  | 1             |         |         | PARENT PART                  |
| 3       | 17211-VA2-0000    | 5.40                 | Air Cleaner Element                | 1             |         |         |                              |
| 4       | 17213-VA2-0000(X) |                      | Air Cleaner Cover Seal             | 1             |         |         | CHILD PART OF 17200-VA2-0001 |
| 5       | 17214-VA2-0000(X) |                      | Air Cleaner Case Seal              | 2             |         |         | CHILD PART OF 17200-VA2-0001 |
| 6       | 17215-VA2-0000(X) |                      | R. Duct. Cap                       | 1             |         |         | CHILD PART OF 17200-VA2-0001 |
| 7       | 17216-VA2-0000(X) |                      | L. Duct. Cap                       | 1             |         |         | CHILD PART OF 17200-VA2-0001 |
| 8       | 17221-VA2-0000    | 5.60                 | Trap Comp.                         | 1             |         |         |                              |
| 9       | 17230-VA2-000     |                      | Air Cleaner Case                   | 1             |         |         | CHILD PART OF 17200-VA2-0001 |
| 10      | 17231-VA2-0001(X) |                      | Air Cleaner Case Cover             | 1             |         |         | CHILD PART OF 17200-VA2-0001 |
| 11      | 17253-VA2-0000    | 4.10                 | Air Cleaner Connecting Tube        | 1             |         |         |                              |
| 12      | 17255-VA2-0000    | 1.80                 | Air Cleaner Connecting Tube Band B | 1             |         |         |                              |
| 13      | 93901-24310       | 0.60                 | Tapping Screw 4x12                 | 2             |         |         | CHILD PART OF 17200-VA2-0001 |
| 14      | 93903-25410       | 0.60                 | Tapping Screw 5x20                 | 4             |         |         | CHILD PART OF 17200-VA2-0001 |
| 15      | 95801-06012-00    | 0.40                 | Flange Bolt 6x12                   | 2             |         |         |                              |

PRICE SHOWN IS PER PIECE. PRODUCT IMAGE PRICES ARE APPROXIMATE GUIDE ONLY.  
PRICES SHOWN ARE SUBJECT TO CHANDE WITHOUT PRIOR NOTICE.

F13

EXHAUST MUFFLER  
 ÔNG XÃ

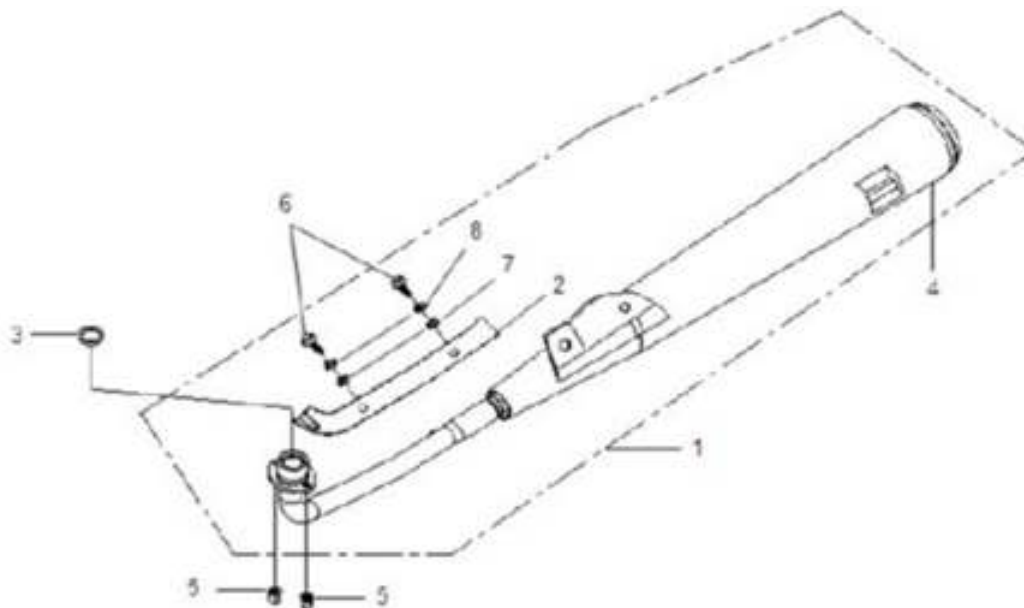

| STT No. | VMEP CODE      | SELLING PRICE RM/PCS | Tên phụ tùng Description | Số lượng Unit | STT No. | Mã E/C. | Ghi chú Remark               |
|---------|----------------|----------------------|--------------------------|---------------|---------|---------|------------------------------|
| 1       | 18000-SAK-0000 | 130.40               | Muffler Ass'y            | 1             |         |         | PARENT PART                  |
| 2       | 18240-SA5-0000 | 10.20                | Exhaust Pipe Protector   | 1             |         |         | CHILD PART OF 18000-SAK-0000 |
| 3       | 18291-X01-0000 | 1.60                 | Exhaust Pipe Gasket      | 1             |         |         |                              |
| 4       | 18300-SAK-000  |                      | Exhaust Muffler Comp.    | 1             |         |         | CHILD PART OF 18000-SAK-0000 |
| 5       | 90308-M36-0000 | 1.10                 | Cap Nut 6mm              | 2             |         |         |                              |
| 6       | 93500-05008-OA | 0.40                 | Pan Screw 5x8            | 2             |         |         |                              |
| 7       | 94101-05000    | 0.40                 | Plain Washer 5mm         | 2             |         |         | CHILD PART OF 18000-SAK-0000 |
| 8       | 94111-05000    | 0.40                 | Spring Washer 5mm        | 2             |         |         | CHILD PART OF 18000-SAK-0000 |
|         |                |                      |                          |               |         |         |                              |
|         |                |                      |                          |               |         |         |                              |
|         |                |                      |                          |               |         |         |                              |
|         |                |                      |                          |               |         |         |                              |

PRICE SHOWN IS PER PIECE. PRODUCT IMAGE PRICES ARE APPROXIMATE GUIDE ONLY.  
 PRICES SHOWN ARE SUBJECT TO CHANDE WITHOUT PRIOR NOTICE.

F14

**STEP BAR-KICK STARTER ARM**  
**CÀN ĐÉ CHÂN-CÀN ĐẠP KHỞI ĐỘNG**

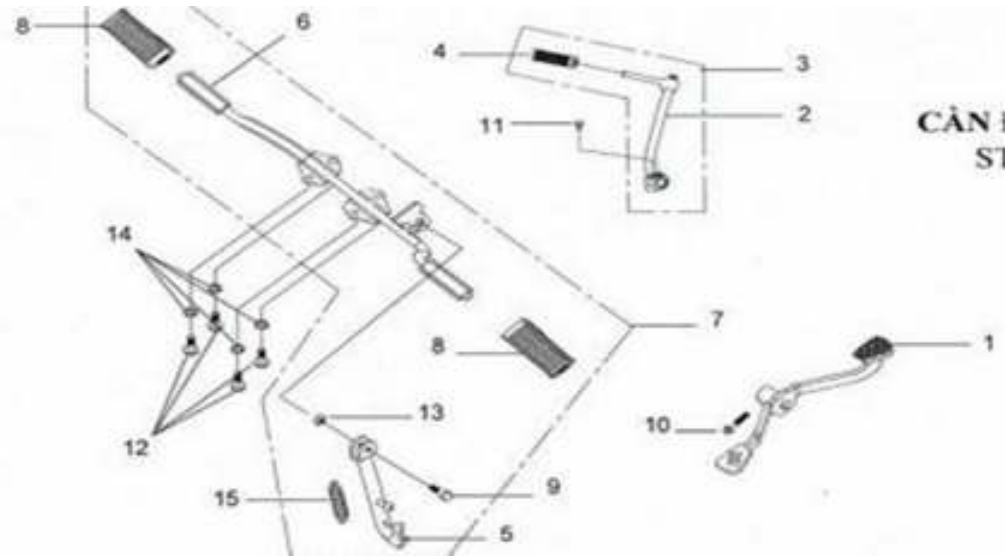

| STT No. | VMEP CODE         | SELLING PRICE RM/PCS | Tên phụ tùng<br>Description | Số lượng<br>Unit | STT No. | Mã E/C. | Ghi chú<br>Remark                           |
|---------|-------------------|----------------------|-----------------------------|------------------|---------|---------|---|
| 1       | 24701-SA5-9000    | 14.90                | Gear Change Pedal           | 1                |         |         |   |
| 2       | 28300-SB7-0000(X) |                      | Kick Starter Arm            | 1                |         |         | CHILD PART OF 2830A-SB7-0000                |
| 3       | 2830A-SB7-0000    | 26.20                | Kick Starter Arm Set        | 1                |         |         | PARENT PART                                 |
| 4       | 28311-SB7-0000(X) |                      | Kick Starter Rubber         | 1                |         |         | CHILD PART OF 2830A-SB7-0000                |
| 5       | 50530-VA3-0000    | 7.80                 | Side Stand Bar Comp.        | 1                |         |         | CHILD PART OF 5061A-VB4-0002                |
| 6       | 50610-SAE-0001    | 29.90                | Step Bar Comp.              | 1                |         |         | CHILD PART OF 5061A-VB4-0002                |
| 7       | 5061A-VB4-0002(X) |                      | Step Bar Ass'y              | 1                |         |         | PARENT PART (Pls order full set child part) |
| 8       | 50661-VB4-0000    | 3.20                 | Step Rubber                 | 2                |         |         | CHILD PART OF 5061A-VB4-0002                |
| 9       | 90108-B06-0001    | 1.60                 | Side Stand Pivot Screw      | 1                |         |         | CHILD PART OF 5061A-VB4-0002                |
| 10      | 92101-06020-0A    | 0.50                 | Hex Bolt 6x20               | 1                |         |         |   |
| 11      | 92101-06028-0H    | 0.60                 | Hex Bolt 6x28               | 1                |         |         |   |
| 12      | 92101-08020-0A    | 0.70                 | Hex Bolt 8x20               | 4                |         |         |   |
| 13      | 94002-10080-0S    | 0.70                 | Hex Nut 10mm                | 1                |         |         | CHILD PART OF 5061A-VB4-0002                |
| 14      | 94111-08000       | 0.50                 | Spring Washer 8 mm          | 4                |         |         |   |
| 15      | 95014-72102-0B    | 2.20                 | Side Stand Spring           | 1                |         |         | CHILD PART OF 5061A-VB4-0002                |

PRICE SHOWN IS PER PIECE. PRODUCT IMAGE PRICES ARE APPROXIMATE GUIDE ONLY.  
 PRICES SHOWN ARE SUBJECT TO CHANGE WITHOUT PRIOR NOTICE.

F15

**MAIN STAND-BRAKE PEDAL  
CHÓNG ĐỨNG-BÀN ĐẠP THẮNG**

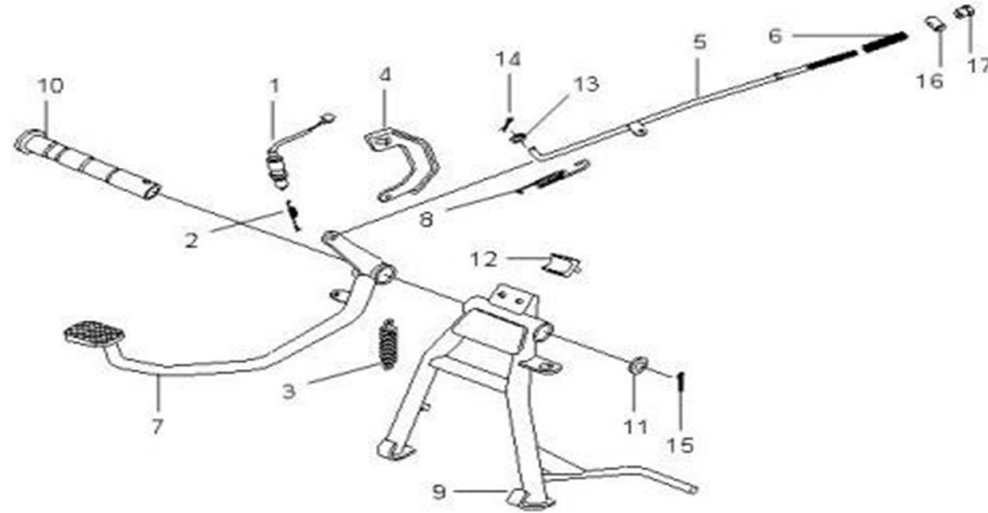

| STT No. | VMEP CODE      | SELLING PRICE RM/PCS | Tên phụ tùng<br>Description | Số lượng<br>Unit | STT No. | Mã E/C. | Ghi chú<br>Remark |
|---------|----------------|----------------------|-----------------------------|------------------|---------|---------|-------------------|
| 1       | 35350-SA5-0001 | 5.60                 | Stop Switch Ass'y           | 1                |         |         |                   |
| 2       | 35357-SA5-0001 | 1.10                 | Stop Switch Spring          | 1                |         |         |                   |
| 3       | 42242-SA1-0000 | 2.20                 | Main Stand Spring           | 1                |         |         |                   |
| 4       | 42246-SA1-0000 | 2.00                 | Main Stand Spring Hook      | 1                |         |         |                   |
| 5       | 43450-SAH-0000 | 4.50                 | Rr. Brake Rod               | 1                |         |         |                   |
| 6       | 43550-SB1-0000 | 0.60                 | Rr. Brake Rod Spring        | 1                |         |         |                   |
| 7       | 46500-SA5-0001 | 14.70                | Rr. Brake Pedal Comp.       | 1                |         |         |                   |
| 8       | 46513-SA1-0000 | 1.10                 | Rr. Brake Return Spring     | 1                |         |         |                   |
| 9       | 50500-SA6-0000 | 12.00                | Main Stand Comp.            | 1                |         |         |                   |
| 10      | 50520-SA1-0001 | 4.90                 | Main Stand Pivot Bolt       | 1                |         |         |                   |
| 11      | 50521-SA1-0000 | 0.70                 | Main Stand Pivot Washer     | 1                |         |         |                   |
| 12      | 50524-SA1-0000 | 1.10                 | Main Stand Stopper Rubber   | 1                |         |         |                   |
| 13      | 94101-05000    | 0.40                 | Plain Washer 5mm            | 1                |         |         |                   |
| 14      | 94201-20151    | 0.70                 | Split Pin 2.0x15            | 1                |         |         |                   |
| 15      | 94201-30280    | 0.70                 | Split Pin 3.0               | 1                |         |         |                   |
| 16      | 95015-32001-00 | 0.70                 | Brake Arm Joint B           | 1                |         |         |                   |
| 17      | 95015-42000-00 | 2.10                 | Adjust Nut B                | 1                |         |         |                   |

PRICE SHOWN IS PER PIECE. PRODUCT IMAGE PRICES ARE APPROXIMATE GUIDE ONLY.  
PRICES SHOWN ARE SUBJECT TO CHANGE WITHOUT PRIOR NOTICE.

F16

REAR FORK-CHAIN CASE  
GẤP SAU-HỘP XÍCH TÀI

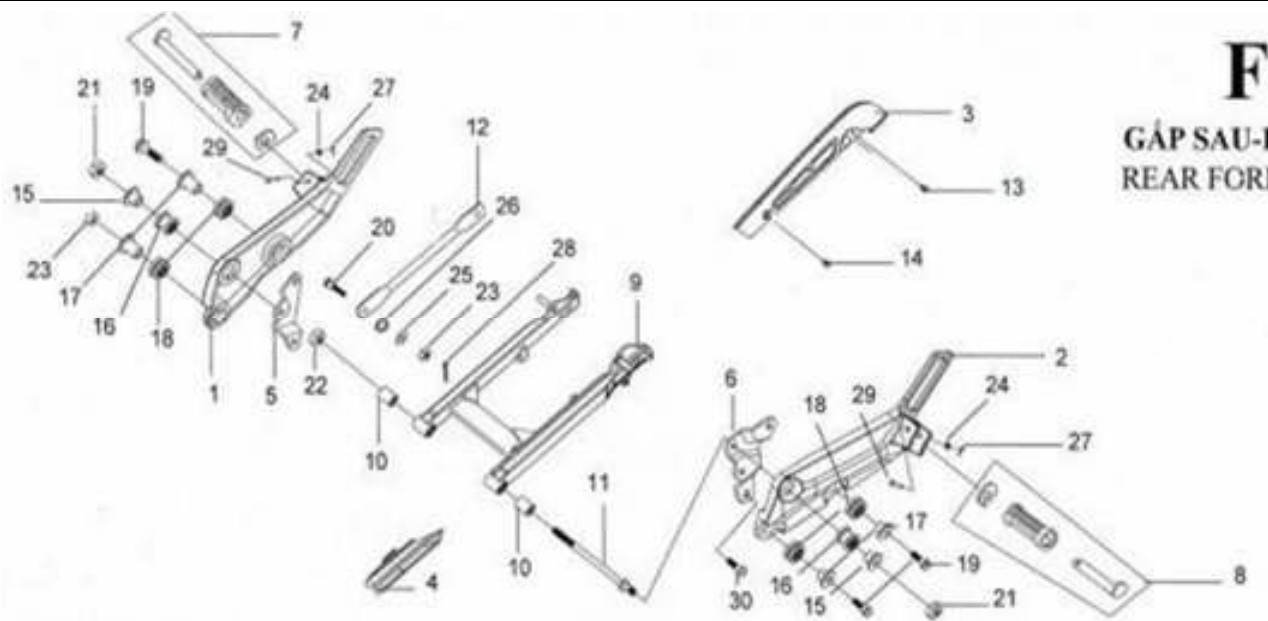

**F**  
GẤP SAU-I  
REAR FORK

| STT No. | VMEP CODE         | SELLING PRICE RM/PCS | Tên phụ tùng<br>Description | Số lượng<br>Unit | STT No. | Mã E/C. | Ghi chú<br>Remark |
|---------|-------------------|----------------------|-----------------------------|------------------|---------|---------|-------------------|
| 1       | 18325-SA6-0000-IC | 41.30                | R. Step Holder              | 1                |         |         |                   |
| 2       | 18425-SA6-0000-IC | 37.50                | L. Step Holder              | 1                |         |         |                   |
| 3       | 4051A-SA5-0000    | 19.50                | Drive Chain Guard           | 1                |         |         |                   |
| 4       | 40591-SA5-0001    | 2.60                 | Drive Chain Case Packing    | 1                |         |         |                   |
| 5       | 50713-SA1-0000    | 6.70                 | R. Pillion Step Stay        | 1                |         |         |                   |
| 6       | 50714-SA5-0000    | 6.40                 | L. Pillion Step Stay        | 1                |         |         |                   |
| 7       | 50830-SAE-0001    | 5.60                 | R. Pillion Step Bar Ass'y   | 1                |         |         |                   |
| 8       | 50840-SAE-0001    | 5.60                 | L. Pillion Step Bar Ass'y   | 1                |         |         |                   |
| 9       | 52100-SAE-0001-IC | 74.90                | Rr. Fork Comp.              | 1                |         |         |                   |
| 10      | 52181-A08-3000    | 5.60                 | Rr. Fork Pivot Rubber Bush  | 2                |         |         |                   |
| 11      | 61251-SA1-0000    | 6.00                 | Rr. Fork Pivot Bolt         | 1                |         |         |                   |
| 12      | 65311-SA1-0000    | 3.90                 | Rr. Brake Stopper Arm       | 1                |         |         |                   |
| 13      | 90111-M9Q-9000    | 0.70                 | Flange Bolt 6mm             | 1                |         |         |                   |
| 14      | 90112-M67-0000    | 0.70                 | Flange Bolt 6mm             | 1                |         |         |                   |
| 15      | 90116-SA1-0000    | 0.80                 | Pillion Collar 10x8         | 2                |         |         |                   |
| 16      | 90117-SA1-0000    | 0.30                 | Pillion Rubber 10           | 2                |         |         |                   |

PRICE SHOWN IS PER PIECE. PRODUCT IMAGE PRICES ARE APPROXIMATE GUIDE ONLY.  
PRICES SHOWN ARE SUBJECT TO CHANGE WITHOUT PRIOR NOTICE.

F16

**REAR FORK-CHAIN CASE**  
**GẤP SAU-HỘP XÍCH TÀI**

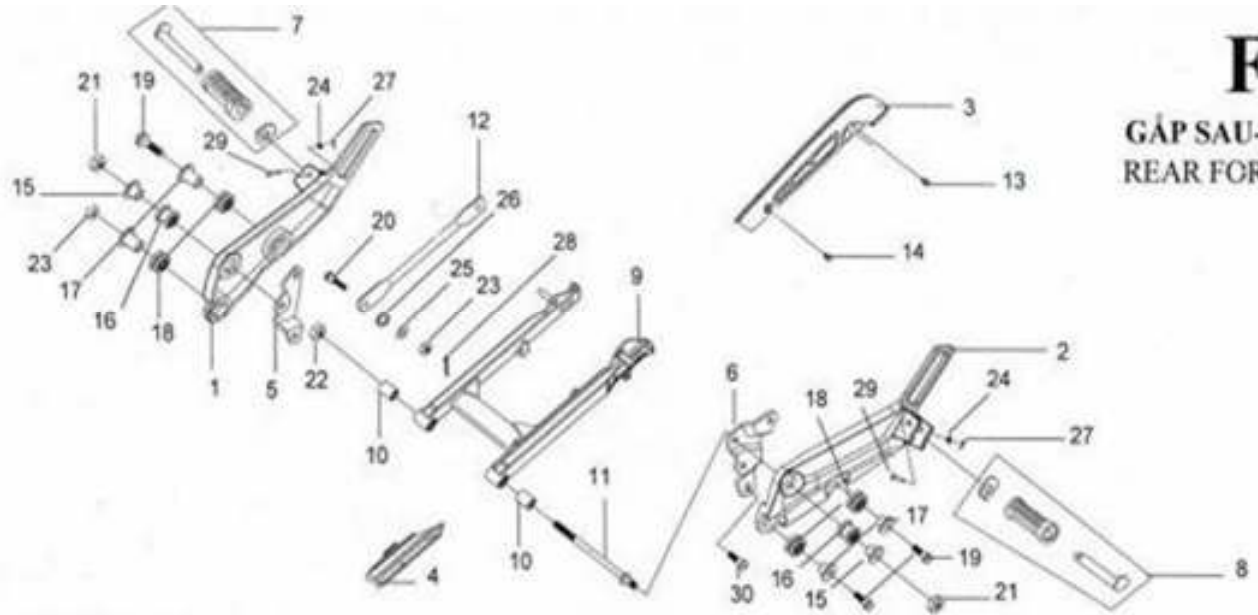

| STT No. | VMEP CODE      | SELLING PRICE RM/PCS | Tên phụ tùng<br>Description | Số lượng<br>Unit | STT No. | Mã E/C. | Ghi chú<br>Remark |
|---------|----------------|----------------------|-----------------------------|------------------|---------|---------|-------------------|
| 17      | 90118-SA1-0000 | 0.50                 | Pillion Collar 8x12         | 4                |         |         |                   |
| 18      | 90119-SA1-0000 | 0.30                 | Pillion Rubber 8            | 4                |         |         |                   |
| 19      | 92101-08028-0A | 0.70                 | Hex Bolt 8x28               | 3                |         |         |                   |
| 20      | 92812-10000    | 1.50                 | Rr. Brake Stopper Arm Bolt  | 1                |         |         |                   |
| 21      | 94001-10000-0S | 0.70                 | Hex Nut 10mm                | 2                |         |         |                   |
| 22      | 94002-10000-0S | 0.70                 | Hex Nut 10mm                | 1                |         |         |                   |
| 23      | 94050-08000    | 0.70                 | Flange Nut 8mm              | 2                |         |         |                   |
| 24      | 94101-06000    | 0.40                 | Plain Washer 6mm            | 2                |         |         |                   |
| 25      | 94101-08000    | 0.50                 | Plain Washer 8mm            | 1                |         |         |                   |
| 26      | 94111-10000-00 | 0.70                 | Spring Washer 10mm          | 1                |         |         |                   |
| 27      | 94201-16150    | 0.70                 | Split Pin 1.6x15            | 2                |         |         |                   |
| 28      | 94201-20151    | 0.70                 | Split Pin 2.0x15            | 1                |         |         |                   |
| 29      | 95015-83000    | 0.70                 | Pillion Step Pin            | 2                |         |         |                   |
| 30      | 95801-08016-08 | 0.80                 | Flange Bolt 8x16            | 1                |         |         |                   |

PRICE SHOWN IS PER PIECE. PRODUCT IMAGE PRICES ARE APPROXIMATE GUIDE ONLY.  
 PRICES SHOWN ARE SUBJECT TO CHANGE WITHOUT PRIOR NOTICE.



F17

**REAR CUSHION**  
**BỘ PHỤ C SAU**

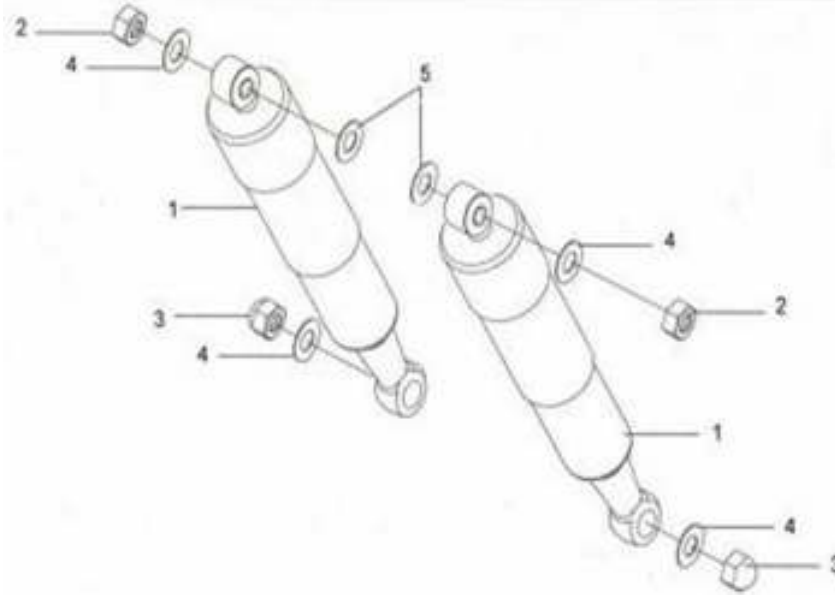

| STT No. | VMEP CODE      | SELLING PRICE RM/PCS | Tên phụ tùng<br>Description | Số lượng<br>Unit | STT No. | Mã E/C. | Ghi chú<br>Remark |
|---------|----------------|----------------------|-----------------------------|------------------|---------|---------|-------------------|
| 1       | 52400-SAE-0002 | 71.70                | Rear Cushion Ass'y          | 2                |         |         |                   |
| 2       | 94001-10000-0S | 0.70                 | Hex Nut 10 mm               | 2                |         |         |                   |
| 3       | 94021-10000    | 2.00                 | Hex Cap Nut 10 mm           | 2                |         |         |                   |
| 4       | 94101-10000-00 | 0.60                 | Plain Washer 10 mm          | 4                |         |         |                   |
| 5       | 94101-12000-00 | 0.60                 | Plain Washer 12 mm          | 2                |         |         |                   |
|         |                |                      |                             |                  |         |         |                   |
|         |                |                      |                             |                  |         |         |                   |
|         |                |                      |                             |                  |         |         |                   |
|         |                |                      |                             |                  |         |         |                   |
|         |                |                      |                             |                  |         |         |                   |
|         |                |                      |                             |                  |         |         |                   |
|         |                |                      |                             |                  |         |         |                   |

PRICE SHOWN IS PER PIECE. PRODUCT IMAGE PRICES ARE APPROXIMATE GUIDE ONLY.  
PRICES SHOWN ARE SUBJECT TO CHANGE WITHOUT PRIOR NOTICE.

F18

**BODY COVER**  
**ÓP SƯỜN**

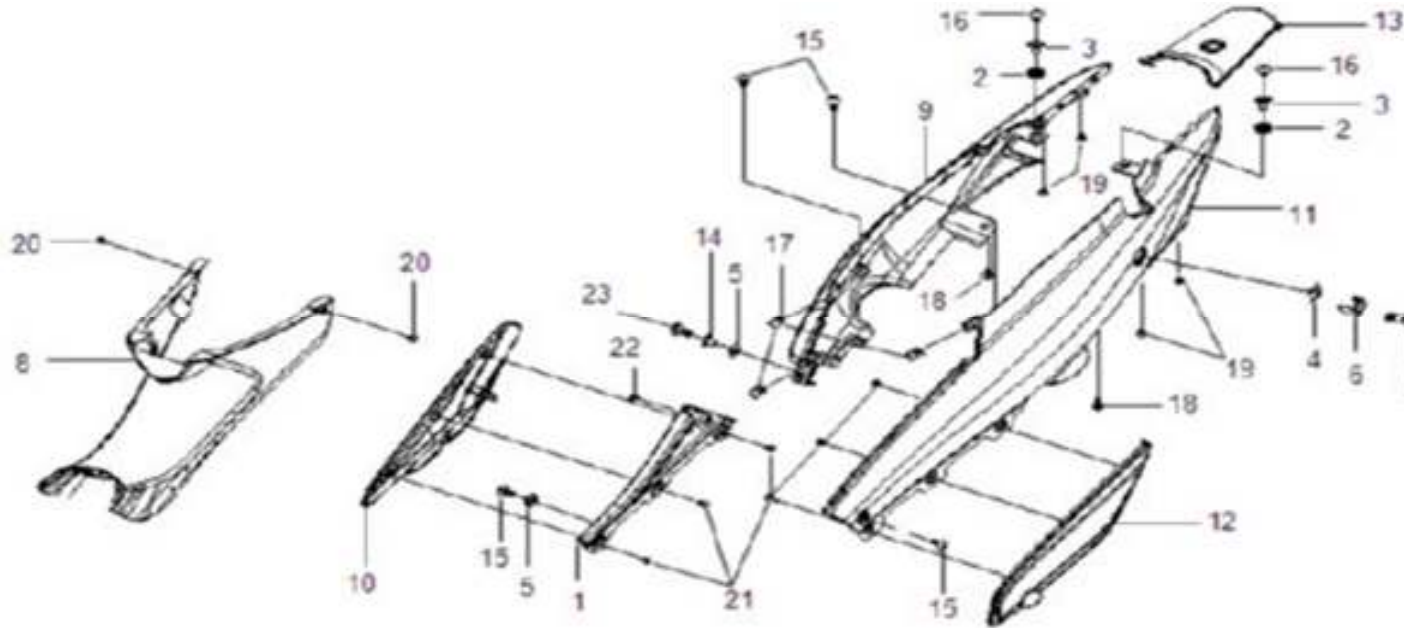

| STT No. | VMEP CODE         | SELLING PRICE RM/PCS | Tên phụ tùng<br>Description | Số lượng<br>Unit | STT No. | Mã E/C. | Ghi chú<br>Remark         |
|---------|-------------------|----------------------|-----------------------------|------------------|---------|---------|---------------------------|
| 1       | 50326-SA5-0001-KB | 4.80                 | Battery Cover               | 1                |         |         | KB-BLACK, RB-RED, DH-BLUE |
| 2       | 64304-X01-0000    | 0.70                 | Fr. Cover Rubber            | 2                |         |         |                           |
| 3       | 64306-X01-0000    | 0.70                 | Fr. Cover Collar            | 2                |         |         |                           |
| 4       | 75581-M9Q-0001    | 3.20                 | Lock Key Set Spring         | 1                |         |         |                           |
| 5       | 77226-M3F-0000    | 0.40                 | Damping Rubber              | 2                |         |         |                           |
| 6       | 77232-F3C-0002    | 1.90                 | Seat Lock Stay              | 1                |         |         |                           |
| 7       | 77239-SA5-0000    | 21.20                | Seat Lock Comp.             | 1                |         |         |                           |
| 8       | 80152-SA5-0000    | 12.10                | Center Cover                | 1                |         |         |                           |
| 9       | 83500-SA5-0004-KB | 38.70                | R. Body Cover               | 1                |         |         | KB-BLACK, RB-RED, DH-BLUE |
| 10      | 83550-SA5-0000-IF | 16.30                | R. Side Plate               | 1                |         |         |                           |
| 11      | 83600-SA5-0004-KB | 38.70                | L. Body Cover               | 1                |         |         | KB-BLACK, RB-RED, DH-BLUE |
| 12      | 83650-SA5-0000-IF | 16.30                | L. Side Plate               | 1                |         |         |                           |
| 13      | 87123-SA5-0002-KB | 7.50                 | Rr. Center Cover            | 1                |         |         | KB-BLACK, RB-RED, DH-BLUE |
| 14      | 90104-VA1-0000    | 0.70                 | Fr. Fork Cover Collar       | 1                |         |         |                           |
| 15      | 90110-GZ0-000A    | 0.70                 | Special Screw 6mm           | 4                |         |         |                           |
| 16      | 90115-VA3-0000    | 1.10                 | Body Cover Bolt 6x18        | 2                |         |         |                           |

PRICE SHOWN IS PER PIECE. PRODUCT IMAGE PRICES ARE APPROXIMATE GUIDE ONLY.  
PRICES SHOWN ARE SUBJECT TO CHANGE WITHOUT PRIOR NOTICE.

F18

**BODY COVER**  
**ÓP SƯỜN**

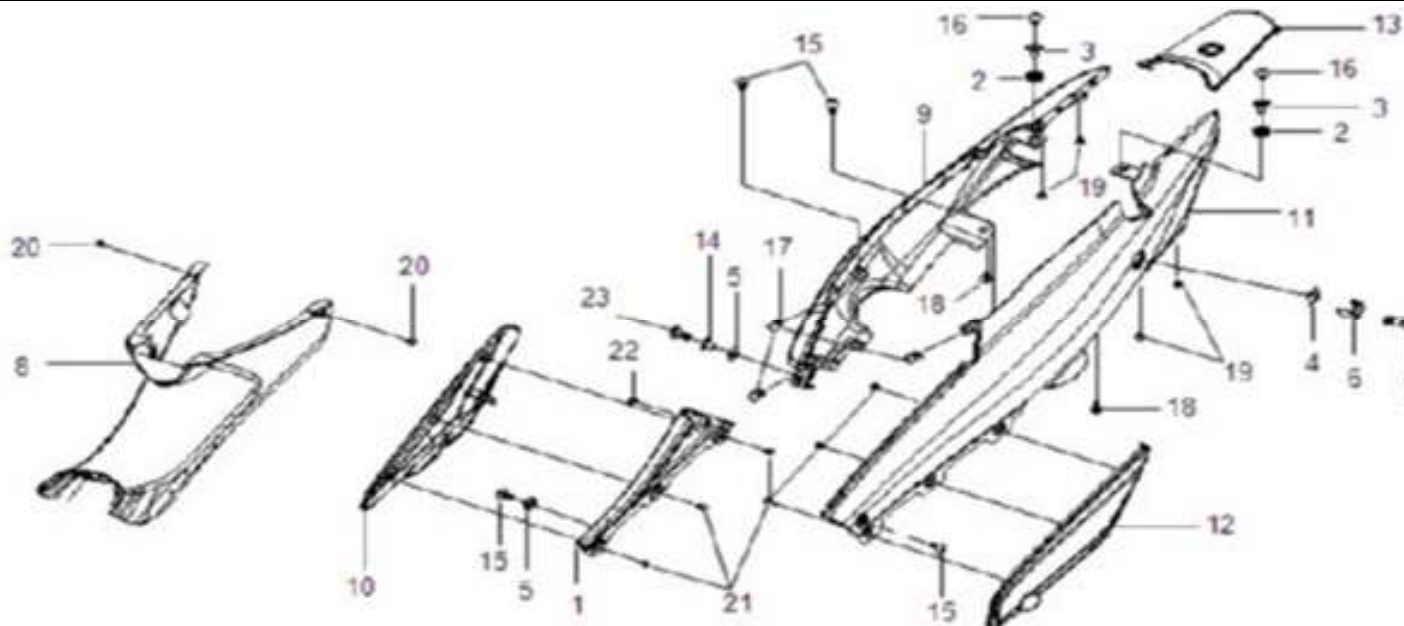

| STT No. | VMEP CODE          | SELLING PRICE RM/PCS | Tên phụ tùng<br>Description | Số lượng<br>Unit | STT No. | Mã E/C. | Ghi chú<br>Remark                    |
|---------|--------------------|----------------------|-----------------------------|------------------|---------|---------|--------------------------------------|
| 17      | 90302-SA4-003B     | 0.70                 | Spring Nut 4mm              | 3                |         |         |                                      |
| 18      | 93404-06012-00     | 0.60                 | Washer Bolt 6x12            | 2                |         |         |                                      |
| 19      | 93903-24220-10     | 0.60                 | Tapping Screw 4x10          | 4                |         |         |                                      |
| 20      | 93903-24380        | 0.60                 | Tapping Screw 4x12          | 2                |         |         |                                      |
| 21      | 93903-34320-00     | 0.60                 | Tapping Screw 4x12          | 6                |         |         |                                      |
| 22      | 93903-44480        | 0.60                 | Tapping Screw 4x16          | 1                |         |         |                                      |
| 23      | 95801-06016-08     | 1.00                 | Flange Bolt 6x16            | 1                |         |         |                                      |
|         | 64000-SAH-0100-KCS | 338.00               | BODY COVER SET              |                  |         |         | KCS - BLACK, RWH - RED<br>BWH - BLUE |
|         |                    |                      |                             |                  |         |         |                                      |
|         |                    |                      |                             |                  |         |         |                                      |
|         |                    |                      |                             |                  |         |         |                                      |
|         |                    |                      |                             |                  |         |         |                                      |
|         |                    |                      |                             |                  |         |         |                                      |
|         |                    |                      |                             |                  |         |         |                                      |

PRICE SHOWN IS PER PIECE. PRODUCT IMAGE PRICES ARE APPROXIMATE GUIDE ONLY.  
PRICES SHOWN ARE SUBJECT TO CHANGE WITHOUT PRIOR NOTICE.

F19

REAR FENDER-TAIL LIGHT  
VỀ SAU-ĐÈN SAU

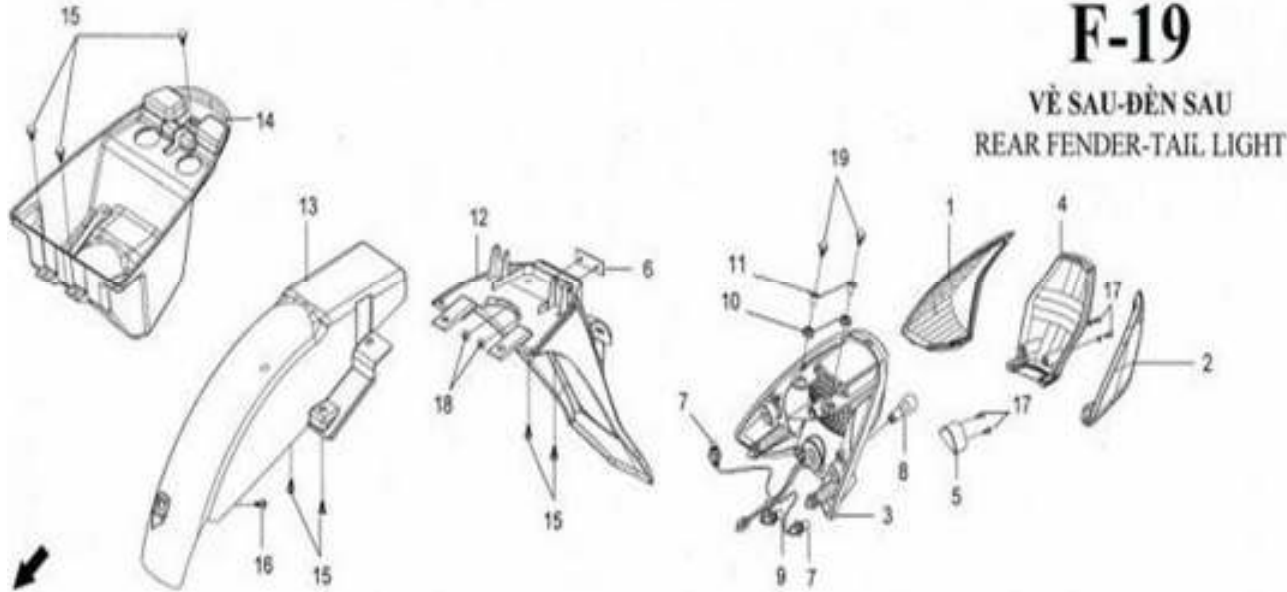

| STT No. | VMEP CODE      | SELLING PRICE RM/PCS | Tên phụ tùng Description | Số lượng Unit | STT No. | Mã E/C. | Ghi chú Remark |
|---------|----------------|----------------------|--------------------------|---------------|---------|---------|----------------|
| 1       | 33602-SA5-0001 | 5.20                 | Rr. R. Winker Lens       | 1             |         |         |                |
| 2       | 33652-SA5-0001 | 5.20                 | Rr. L. Winker Lens       | 1             |         |         |                |
| 3       | 33701-SA5-0001 | 18.70                | Tail Light Base          | 1             |         |         |                |
| 4       | 33702-SA5-0000 | 13.80                | Tail Light Lens          | 1             |         |         |                |
| 5       | 33705-SA5-0000 | 5.20                 | Licence Lens             | 1             |         |         |                |
| 6       | 33741-E51-0001 | 4.90                 | Rr. Reflector            | 1             |         |         |                |
| 7       | 34905-M9Q-0000 | 2.90                 | Winker Bulb              | 2             |         |         |                |
| 8       | 34906-M9Q-0000 | 13.10                | Tail Light Bulb          | 1             |         |         |                |
| 9       | 34908-M9Q-0000 | 1.50                 | Rr. Licence Bulb         | 1             |         |         |                |
| 10      | 64304-X01-0000 | 0.70                 | Fr. Cover Rubber         | 2             |         |         |                |
| 11      | 64306-X01-0000 | 0.70                 | Fr. Cover Collar         | 2             |         |         |                |
| 12      | 80100-SA5-0000 | 15.10                | Rr. Fender               | 1             |         |         |                |
| 13      | 80200-SA5-0001 | 9.10                 | Rr. Center Fender        | 1             |         |         |                |
| 14      | 83400-SA5-0000 | 11.40                | Tool Box                 | 1             |         |         |                |
| 15      | 90111-VA2-0000 | 0.70                 | Flange Bolt 6mm          | 7             |         |         |                |
| 16      | 93404-06016-00 | 0.80                 | Washer Bolt 6x16         | 1             |         |         |                |

PRICE SHOWN IS PER PIECE. PRODUCT IMAGE PRICES ARE APPROXIMATE GUIDE ONLY.  
PRICES SHOWN ARE SUBJECT TO CHANDE WITHOUT PRIOR NOTICE.

F19

REAR FENDER-TAIL LIGHT  
VỀ SAU-ĐÈN SAU

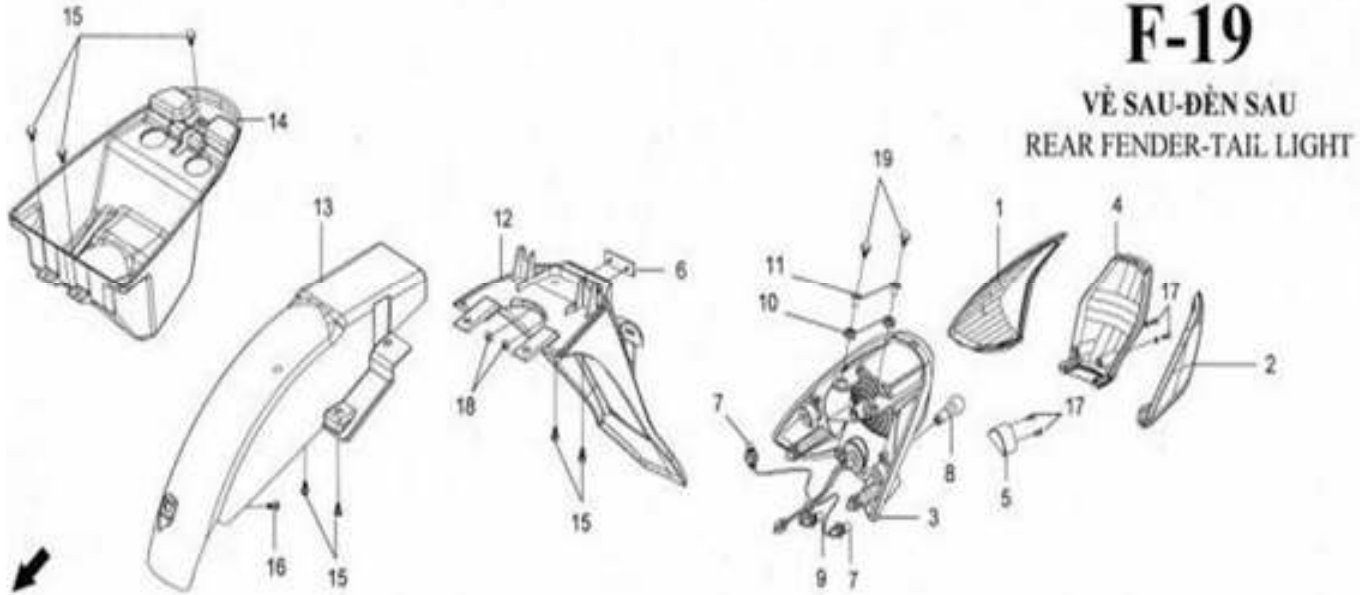

| STT No. | VMEP CODE      | SELLING PRICE RM/PCS | Tên phụ tùng Description | Số lượng Unit | STT No. | Mã E/C. | Ghi chú Remark |
|---------|----------------|----------------------|--------------------------|---------------|---------|---------|----------------|
| 17      | 93901-34320    | 0.60                 | Tapping Screw 4x12       | 4             |         |         |                |
| 18      | 94050-05080-00 | 0.70                 | Flange Nut 5mm           | 2             |         |         |                |
| 19      | 95801-06020-00 | 0.70                 | Flange Bolt 6x20         | 2             |         |         |                |
| 20      | 33700-SA5-0001 | 32.60                | Tail Light Ass'y         | 1             |         |         |                |
|         |                |                      |                          |               |         |         |                |
|         |                |                      |                          |               |         |         |                |
|         |                |                      |                          |               |         |         |                |
|         |                |                      |                          |               |         |         |                |
|         |                |                      |                          |               |         |         |                |
|         |                |                      |                          |               |         |         |                |
|         |                |                      |                          |               |         |         |                |
|         |                |                      |                          |               |         |         |                |
|         |                |                      |                          |               |         |         |                |
|         |                |                      |                          |               |         |         |                |
|         |                |                      |                          |               |         |         |                |
|         |                |                      |                          |               |         |         |                |

PRICE SHOWN IS PER PIECE. PRODUCT IMAGE PRICES ARE APPROXIMATE GUIDE ONLY.  
PRICES SHOWN ARE SUBJECT TO CHANGE WITHOUT PRIOR NOTICE.

**F20**

**REAR CARRIER  
TAY NĂM**

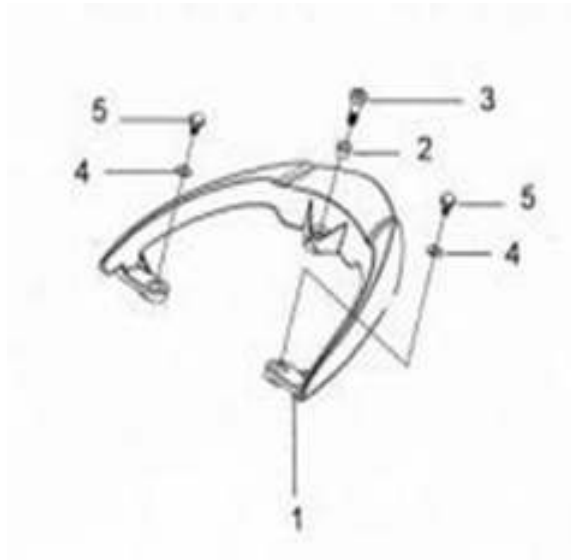

| STT No. | VMEP CODE      | SELLING PRICE RM/PCS | Tên phụ tùng<br>Description | Số lượng<br>Unit | STT No. | Mã E/C. | Ghi chú<br>Remark |
|---------|----------------|----------------------|-----------------------------|------------------|---------|---------|-------------------|
| 1       | 81200-SA5-9000 | 24.20                | Rr. Carrier                 | 1                |         |         |                   |
| 2       | 81204-H6T-0000 | 3.90                 | Rr. Carrier Collar          | 1                |         |         |                   |
| 3       | 90186-VA6-0001 | 2.30                 | Socket Bolt 8x25            | 1                |         |         |                   |
| 4       | 94103-08000    | 0.50                 | Plain Washer 8mm            | 2                |         |         |                   |
| 5       | 95801-08020-00 | 1.10                 | Flange Bolt 8x20            | 2                |         |         |                   |
|         |                |                      |                             |                  |         |         |                   |
|         |                |                      |                             |                  |         |         |                   |
|         |                |                      |                             |                  |         |         |                   |
|         |                |                      |                             |                  |         |         |                   |
|         |                |                      |                             |                  |         |         |                   |
|         |                |                      |                             |                  |         |         |                   |
|         |                |                      |                             |                  |         |         |                   |
|         |                |                      |                             |                  |         |         |                   |

PRICE SHOWN IS PER PIECE. PRODUCT IMAGE PRICES ARE APPROXIMATE GUIDE ONLY.  
PRICES SHOWN ARE SUBJECT TO CHANGE WITHOUT PRIOR NOTICE.

F21

**WIRE HARNESS - BATTERY**  
**DÂY ĐIỆN - BÌNH ĐIỆN**

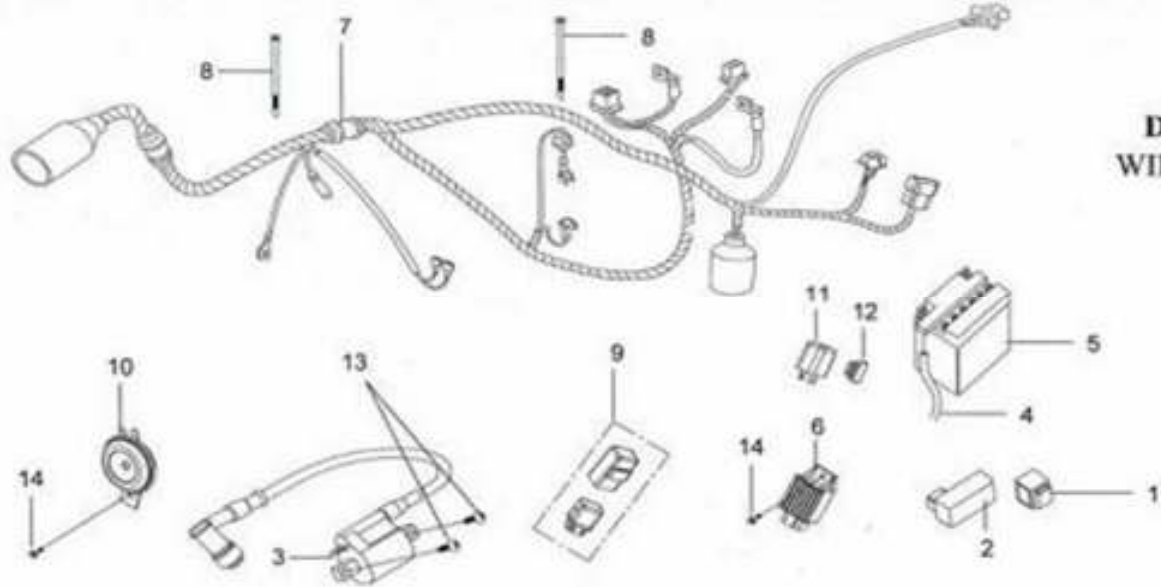

D  
WIF

| STT No. | VMEP CODE      | SELLING PRICE RM/PCS | Tên phụ tùng<br>Description | Số lượng<br>Unit | STT No. | Mã E/C. | Ghi chú<br>Remark |
|---------|----------------|----------------------|-----------------------------|------------------|---------|---------|-------------------|
| 1       | 30400-SA5-0000 | 30.00                | C.D.I Unit Cushion          | 1                |         |         |                   |
| 2       | 30400-SA5-0000 | 30.00                | C.D.I Unit Comp.            | 1                |         |         |                   |
| 3       | 30500-SA5-0000 | 26.10                | Ignition Coil Ass'y         | 1                |         |         |                   |
| 4       | 31502-VA3-0000 | 2.10                 | Battery Breather Tube       | 1                |         |         |                   |
| 5       | 3150A-VA2-000  |                      | Battery Set                 | 1                |         |         |                   |
| 6       | 31600-VN7-0000 | 41.20                | Regulator Rectifier Comp.   | 1                |         |         |                   |
| 7       | 32100-SA5-0002 | 44.90                | Wire Harness                | 1                |         |         |                   |
| 8       | 32161-T15-0002 | 1.00                 | Wire Band 250               | 2                |         |         |                   |
| 9       | 34600-SA1-0000 | 13.00                | Start Relay Ass'y           | 1                |         |         |                   |
| 10      | 38110-SA5-0003 | 11.20                | Horn Comp.                  | 1                |         |         |                   |
| 11      | 38200-SA1-0000 | 9.80                 | Winker Relay Ass'y.         | 1                |         |         |                   |
| 12      | 38306-SB1-000  |                      | Winker Relay Rubber         | 1                |         |         |                   |
| 13      | 93500-05016-0H | 0.40                 | Pan Screw 5x16              | 2                |         |         |                   |
| 14      | 95801-06012-00 | 0.40                 | Flange Bolt 6x12            | 2                |         |         |                   |
| 15      | 30700-M8Q-0000 | 7.90                 | Noise Suppressor Cap Ass'Y  | 1                |         |         |                   |

PRICE SHOWN IS PER PIECE. PRODUCT IMAGE PRICES ARE APPROXIMATE GUIDE ONLY.  
 PRICES SHOWN ARE SUBJECT TO CHANGE WITHOUT PRIOR NOTICE.

F22

**FRAME BODY**  
**KHUNG XE**

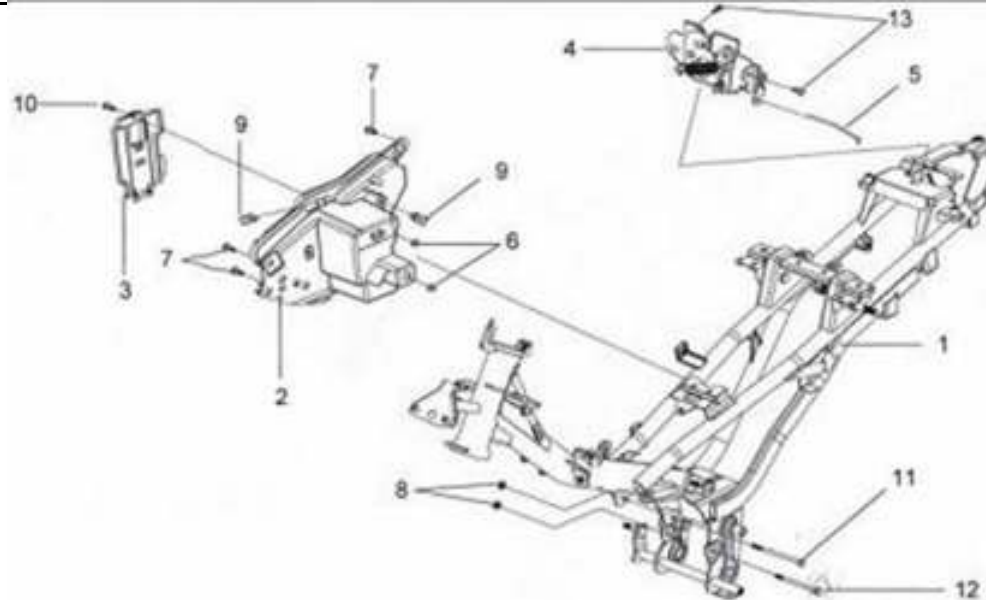

| STT No. | VMEP CODE      | SELLING PRICE RM/PCS | Tên phụ tùng<br>Description    | Số lượng<br>Unit | STT No. | Mã E/C. | Ghi chú<br>Remark |
|---------|----------------|----------------------|--------------------------------|------------------|---------|---------|-------------------|
| 1       | 50100-SAE-0000 | 500.00               | Frame Body Comp.               | 1                |         |         |                   |
| 2       | 50320-SA5-0000 | 7.20                 | Battery Case                   | 1                |         |         |                   |
| 3       | 50322-SA5-0000 | 7.20                 | Battery Tray                   | 1                |         |         |                   |
| 4       | 77230-SA5-0000 | 12.30                | Seat Catch Comp.               | 1                |         |         |                   |
| 5       | 77240-SA5-0001 | 4.00                 | Seat Lock Cable                | 1                |         |         |                   |
| 6       | 83551-SB1-0000 | 0.40                 | Side Cover Grommet             | 2                |         |         |                   |
| 7       | 90111-VA2-0000 | 0.70                 | Flange Bolt 6 mm               | 3                |         |         |                   |
| 8       | 90309-M9Q-0000 | 1.90                 | Flange Nut 8 mm                | 2                |         |         |                   |
| 9       | 90344-SA1-0000 | 0.20                 | Special Clip 6 mm              | 2                |         |         |                   |
| 10      | 93891-06016-07 | 0.60                 | Washer Screw 6x16              | 1                |         |         |                   |
| 11      | 95301-08100-00 | 2.00                 | Engine Hanger Under Bolt 8x100 | 1                |         |         |                   |
| 12      | 95301-08110-00 | 2.00                 | Engine Hanger Upper Bolt 8x110 | 1                |         |         |                   |
| 13      | 95801-06012-00 | 0.40                 | Flange Bolt 6x12               | 2                |         |         |                   |

PRICE SHOWN IS PER PIECE. PRODUCT IMAGE PRICES ARE APPROXIMATE GUIDE ONLY.  
PRICES SHOWN ARE SUBJECT TO CHANGE WITHOUT PRIOR NOTICE.



**F23**

**CAUTION MARK-LABEL  
NHÃN CHỈ DẪN**

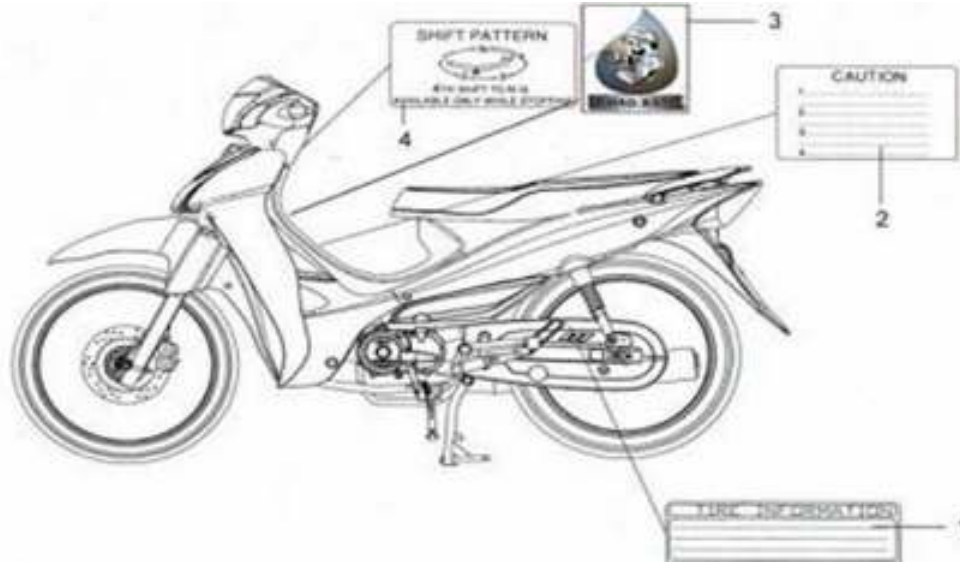

| STT No. | VMEP CODE         | SELLING PRICE RM/PCS | Tên phụ tùng Description  | Số lượng Unit | STT No. | Mã E/C. | Ghi chú Remark |
|---------|-------------------|----------------------|---------------------------|---------------|---------|---------|----------------|
| 1       | 87505-X01-0001-L1 | 0.70                 | Tire Caution Mark         | 1             |         |         |                |
| 2       | 87508-VR3-0000    | 0.40                 | Air Cleaner Caution Label | 1             |         |         |                |
| 3       | 87510-KAG-0000    | 2.00                 | Economy Fuel Label        | 1             |         |         |                |
| 4       | 87512-VA2-0000    | 2.00                 | Shift Pattern Label       | 1             |         |         |                |
|         |                   |                      |                           |               |         |         |                |
|         |                   |                      |                           |               |         |         |                |
|         |                   |                      |                           |               |         |         |                |
|         |                   |                      |                           |               |         |         |                |
|         |                   |                      |                           |               |         |         |                |
|         |                   |                      |                           |               |         |         |                |
|         |                   |                      |                           |               |         |         |                |
|         |                   |                      |                           |               |         |         |                |
|         |                   |                      |                           |               |         |         |                |
|         |                   |                      |                           |               |         |         |                |

PRICE SHOWN IS PER PIECE. PRODUCT IMAGE PRICES ARE APPROXIMATE GUIDE ONLY.  
PRICES SHOWN ARE SUBJECT TO CHANGE WITHOUT PRIOR NOTICE.

F24

**STRIPE  
TEM XE**

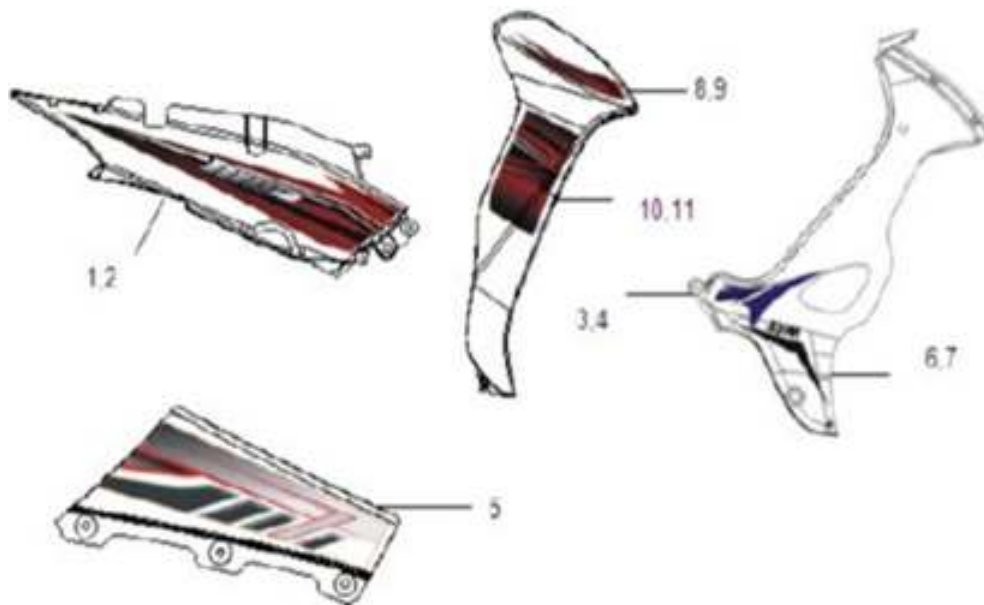

| STT No. | VMEP CODE         | SELLING PRICE RM/PCS | Tên phụ tùng Description    | Số lượng Unit | STT No. | Mã E/C. | Ghi chú Remark                 |
|---------|-------------------|----------------------|-----------------------------|---------------|---------|---------|--------------------------------|
| 1       | 87121-SAH-0004-T1 | 15.60                | R. Body Cover Stripe        | 1             |         |         | T1-BLACK, T2-RED, 0005-T3-BLUE |
| 2       | 87122-SAH-0004-T1 | 20.40                | L. Body Cover Stripe        | 1             |         |         | T1, T2, 0005-T3-BLUE           |
| 3       | 87125-SAH-0001-T1 | 6.50                 | R. Main Pipe Cover Stripe A | 1             |         |         | T1, T2, 0002-T3-BLUE           |
| 4       | 87126-SAH-0001-T1 | 6.50                 | L. Main Pipe Cover Stripe A | 1             |         |         | T1, T2, 0002-T3-BLUE           |
| 5       | 87127-SAH-0003-T1 | 5.20                 | Battery Cover Stripe        | 1             |         |         | T1, T2, 0004-T3-BLUE           |
| 6       | 87131-SAH-0000-T1 | 2.60                 | R. Main Pipe Cover Stripe B | 1             |         |         | T1, T2, 0001-T3-BLUE           |
| 7       | 87132-SAH-0000-T1 | 2.60                 | L. Main Pipe Cover Stripe B | 1             |         |         | T1, T2, 0001-T3-BLUE           |
| 8       | 87133-SAH-0004-T1 | 3.70                 | R. Front Cover Stripe A     | 1             |         |         | T1, T2, 0005-T3-BLUE           |
| 9       | 87134-SAH-0003-T1 | 3.70                 | L. Front Cover Stripe A     | 1             |         |         | T1, T2, 0004-T3-BLUE           |
| 10      | 87135-SAH-0004-T1 | 6.70                 | R. Front Cover Stripe B     | 1             |         |         | T1, T2, 0005-T3-BLUE           |
| 11      | 87136-SAH-0004-T1 | 6.70                 | L. Front Cover Stripe B     | 1             |         |         | T1, T2, 0005-T3-BLUE           |
|         | 87000-SAH-0100-T1 | 53.20                | STRIPE SET                  |               |         |         | T1, T2, T3                     |

PRICE SHOWN IS PER PIECE. PRODUCT IMAGE PRICES ARE APPROXIMATE GUIDE ONLY.  
PRICES SHOWN ARE SUBJECT TO CHANGE WITHOUT PRIOR NOTICE.

F25

**TOOL ASSY**  
**BỘ DỤNG CỤ**

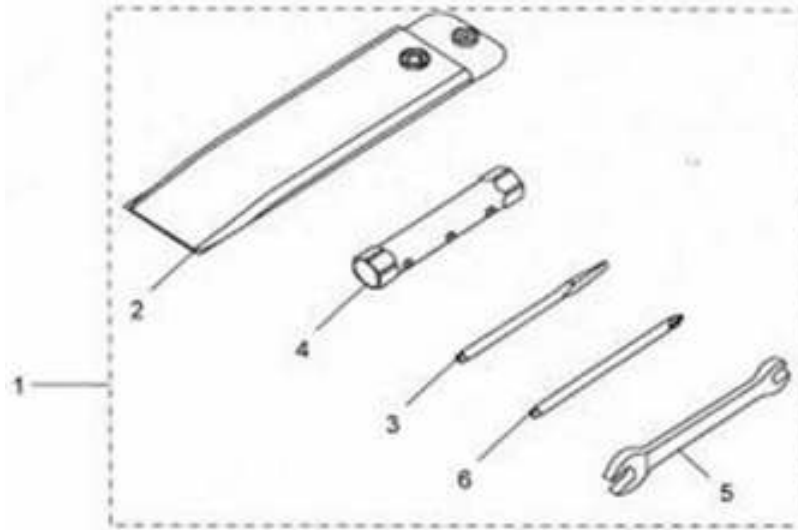

| STT No. | VMEP CODE         | SELLING PRICE RM/PCS | Tên phụ tùng Description | Số lượng Unit | STT No. | Mã E/C. | Ghi chú Remark |
|---------|-------------------|----------------------|--------------------------|---------------|---------|---------|----------------|
| 1       | 89010-M51-0000-OA | 11.20                | Tool Ass'y               | 1             |         |         |                |
|         |                   |                      |                          |               |         |         |                |
|         |                   |                      |                          |               |         |         |                |
|         |                   |                      |                          |               |         |         |                |
|         |                   |                      |                          |               |         |         |                |
|         |                   |                      |                          |               |         |         |                |
|         |                   |                      |                          |               |         |         |                |
|         |                   |                      |                          |               |         |         |                |
|         |                   |                      |                          |               |         |         |                |
|         |                   |                      |                          |               |         |         |                |
|         |                   |                      |                          |               |         |         |                |
|         |                   |                      |                          |               |         |         |                |
|         |                   |                      |                          |               |         |         |                |
|         |                   |                      |                          |               |         |         |                |
|         |                   |                      |                          |               |         |         |                |
|         |                   |                      |                          |               |         |         |                |
|         |                   |                      |                          |               |         |         |                |

PRICE SHOWN IS PER PIECE. PRODUCT IMAGE PRICES ARE APPROXIMATE GUIDE ONLY. PRICES SHOWN ARE SUBJECT TO CHANGE WITHOUT PRIOR NOTICE.

**BAÛNG TRA MAÛ SỐ**  
**PART NO. INDEX**

| Mã số phụ tùng<br>Part. No. | Số thứ tự<br>No. | Mã số phụ tùng<br>Part. No. | Số thứ tự<br>No. | Mã số phụ tùng<br>Part. No. | Số thứ tự<br>No. | Mã số phụ tùng<br>Part. No. | Số thứ tự<br>No. | Mã số phụ tùng<br>Part. No. | Số thứ tự<br>No. |
|-----------------------------|------------------|-----------------------------|------------------|-----------------------------|------------------|-----------------------------|------------------|-----------------------------|------------------|
|                             | <b>10000</b>     | 12396-SAE-0000              | F10              | 14550-M8Q-0000              | E04              | 16802-SA5-0002              | F11              |                             | <b>20000</b>     |
| 11100-SAB-0002              | E14              | 13000-VA1-0002              | E15              | 14566-A08-0101              | E04              | 16820-SA5-0001              | F11              | 22000-A05-0000              | E08              |
| 11191-VN7-0000              | E14              | 13010-VA2-0000              | E15              | 14610-VA2-0001              | E04              | 16920-SB1-0000              | F11              | 22100-A05-0000              | E08              |
| 11200-SAB-0000              | E14              | 13012-VA2-3050              | E15              | 14615-VA2-0000              | E04              | 17110-SM1-0000-VN           | E02              | 22101-A05-3001(X)           | E07              |
| 11321-A01-A000              | E12              | 13013-VA2-3050              | E15              | 14670-VA2-0001              | E04              | 17200-VA2-0001              | F12              | 2210B-A05-0001-VN           | E07              |
| 11330-VA2-0011-IC           | E06              | 13014-VA2-3050              | E15              | 14675-VA2-0000              | E04              | 17211-VA2-0000              | F12              | 22111-M3G-0100              | E07              |
| 11338-M3G-0003              | E06              | 13015-VA2-3050              | E15              | 14711-VA2-0001              | E03              | 17213-VA2-0000(X)           | F12              | 22112-M3G-0100              | E07              |
| 11341-VA2-0000              | E10              | 13101-VA2-0000              | E15              | 14721-VA2-0001              | E03              | 17214-VA2-0000(X)           | F12              | 22121-A05-0000              | E08              |
| 11360-VA2-9000              | E10              | 13102-VA2-3050              | E15              | 14751-M8Q-0000              | E03              | 17215-VA2-0000(X)           | F12              | 22201-107-0000-A            | E08              |
| 11394-VN7-0000              | E06              | 13103-VA2-3050              | E15              | 14761-M8Q-0000              | E03              | 17216-VA2-0000(X)           | F12              | 22300-A05-0000-VN           | E07              |
| 11395-VN7-0000              | E10              | 13104-VA2-3050              | E15              | 14771-A01-A000              | E03              | 17221-VA2-0000              | F12              | 22311-107-0002              | E08              |
| 12101-A04-A000              | E05              | 13105-VA2-3050              | E15              | 14775-M9Q-0000              | E03              | 17230-VA2-000               | F12              | 22350-M3G-0101              | E07              |
| 12191-VN7-0000              | E05              | 13111-A04-A000              | E15              | 14781-A01-A000              | E03              | 17231-VA2-0001(X)           | F12              | 22351-A05-0000              | E08              |
| 12200-SA5-0001-VN           | E02              | 13121-VA2-000               | E15              | 15100-VA2-0004              | E09              | 17253-VA2-0000              | F12              | 22361-A05-0002              | E08              |
| 12209-H6B-0000              | E03              | 13131-A31-000               | E15              | 15133-VA2-0001              | E09              | 17255-VA2-0000              | F12              | 22401-M3G-0001              | E08              |
| 1220A-A04-A002              | E02              | 13141-VA2-000               | E15              | 15311-VA2-0002              | E09              | 17500-SA5-0010              | F11              | 22530-M3G-0101              | E07              |
| 12225-VA2-3002              | E02              | 13201-VA1-0001              | E15              | 15321-VA2-0002              | E09              | 17620-VA3-0000              | F11              | 22606-M3G-0000              | E07              |
| 12226-VA2-3002              | E02              | 13310-VD3-3002              | E15              | 15331-VA2-0001              | E09              | 17910-SAH-0000              | F02              | 22630-M3G-0001              | E07              |
| 12237-GB4-6812              | E02              | 13321-VD3-3003              | E15              | 15332-VA2-0001              | E09              | 17950-VAH-A000              | F02              | 22641-M3G-0100              | E07              |
| 12245-GB4-6812              | E02              | 13381-VA2-3001              | E15              | 15341-VA2-0001              | E15              | 1795A-VAH-0000              | F02              | 22711-SB1-0000              | E16              |
| 12251-VA2-0001              | E02              | 14100-VA2-0003              | E03              | 15382-VA2-0001              | E09              | 18000-SAK-0000              | F13              | 22810-VA2-0000              | E06              |
| 12301-A01-A000              | E01              | 14150-VAH-0001-VN           | E03              | 15421-M8Q-0000              | E09              | 18240-SA5-0000              | F13              | 22820-A01-A000              | E06              |
| 12331-A01-A000              | E01              | 14311-VA2-3000              | E15              | 15436-M3G-0100              | E07              | 18291-X01-0000              | F13              | 22820-M3G-0001              | E06              |
| 12341-A04-A000              | E01              | 14321-VA2-0001              | E04              | 15439-VA2-0000              | E07              | 18300-SAK-000               | F13              | 22821-M3G-0001              | E06              |
| 12342-X01-0000              | E14              | 14431-M8Q-0000              | E03              | 1565A-VA1-0000              | E06              | 18325-SA6-0000-IC           | F16              | 22822-M3G-0000(X)           | E06              |
| 12342-X01-0000              | F12              | 14451-M8Q-0000              | E03              | 1576A-VA2-0006(X)           | E14              | 18425-SA6-0000-IC           | F16              | 22823-M3G-0000(X)           | E06              |
| 12361-M9Q-0000              | E01              | 14500-A01-A000              | E04              | 16100-A04-A003-VN           | E19              | 1CS 25H X 62L               | E12              | 22864-VA2-0000              | E06              |
| 12391-VN7-0000              | E01              | 14502-M8Q-0000              | E04              | 16101-VA6-0000              | E19              | 1CS 25H X 90L               | E04              | 23117-M3G-0100              | E07              |
| 12394-VN7-0000              | E01              | 14531-A08-0000              | E04              | 16201-VN7-0000              | E02              | 1CS 428H X 102L             | F09              | 23120-A05-0000(X)           | E07              |
| 12395-VN7-0000              | E01              | 14541-M8Q-0100              | E04              | 16211-A01-A000              | E02              |                             |                  | 23122-A05-0000(X)           | E07              |

PRICE SHOWN IS PER PIECE. PRODUCT IMAGE PRICES ARE APPROXIMATE GUIDE ONLY.  
PRICES SHOWN ARE SUBJECT TO CHANGE WITHOUT PRIOR NOTICE.

INDEX

**BAŢNG TRA MAŢOÁ**  
**PART NO. INDEX**

| Mã số phụ tùng<br>Part. No. | Số thứ tự<br>No. | Mã số phụ tùng<br>Part. No. | Số thứ tự<br>No. | Mã số phụ tùng<br>Part. No. | Số thứ tự<br>No. | Mã số phụ tùng<br>Part. No. | Số thứ tự<br>No. | Mã số phụ tùng<br>Part. No. | Số thứ tự<br>No. |
|-----------------------------|------------------|-----------------------------|------------------|-----------------------------|------------------|-----------------------------|------------------|-----------------------------|------------------|
| 23124-VA2-0001              | E07              | 24641-M8Q-0000(X)           | E17              | 31200-VA2-0003              | E13              | 35100-SA5-0000              | F03              | 42305-SAE-0002              | F09              |
| 23126-A05-3000(X)           | E07              | 24651-M8Q-0000              | E17              | 31502-VA3-0000              | F21              | 35150-SAF-0000              | F03              | 42313-SAH-0000              | F08              |
| 23211-VA2-0000              | E16              | 24652-A08-0001              | E17              | 3150A-VA2-000               | F21              | 35160-SAF-0000              | F03              | 4260A-SAE-0002(X)           | F09              |
| 23217-M3G-0002              | E08              | 24701-SA5-9000              | F14              | 31600-VN7-0000              | F21              | 35170-SAF-0000              | F03              | 4260B-SAH-010               | F09              |
| 23221-VA2-0001              | E16              | 28102-M8Q-0000              | E12              | 32100-SA5-0002              | F21              | 35180-SAF-0000              | F03              | 42610-VA3-0000              | F09              |
| 23421-VA2-0001              | E16              | 28103-M8Q-0000              | E12              | 32161-T15-0002              | F21              | 35200-M9Q-0001              | F03              | 42620-X01-0000              | F09              |
| 23422-VA2-0000              | E16              | 28110-A01-A001              | E12              | 32961-VA2-0000              | E10              | 35342-M3G-0000              | F02              | 42653-001-0041              | F09              |
| 23431-VA2-0000              | E16              | 28117-A05-0000-VN           | E12              | 33100-SAF-0001              | F01              | 35350-SA5-0001              | F15              | 42701-SAH-0001-VN           | F09              |
| 23441-VA2-0001              | E16              | 28120-A01-0000              | E12              | 33102-SAF-0000              | F01              | 35357-SA5-0001              | F15              | 42710-SAH-0000              | F09              |
| 23451-VA2-0000              | E16              | 28125-M7Q-0001              | E12              | 33106-SAF-0000              | F01              | 3575A-VA2-0002              | E10              | 42753-VVA-0000              | F07              |
| 23461-VA2-0000              | E16              | 28126-253-0305              | E12              | 33402-VD3-0000              | F03              | 37200-SAH-0000              | F01              | 42753-VVA-0000              | F09              |
| 23471-VA2-0000              | E16              | 28128-A01-0000              | E12              | 33406-VD3-0000              | F03              | 37211-SAF-0000              | F01              | 43000-VDA-0000(X)           | F08              |
| 23481-VA2-0001              | E16              | 28211-178-0000              | E18              | 3340A-VD3-0002              | F03              | 37800-SA1-0000              | F11              | 43100-X01-0202-SE           | F08              |
| 23802-M36-0000              | E16              | 28221-A13-0000              | E18              | 33411-VD3-0001              | F03              | 38110-SA5-0003              | F21              | 43141-A02-0103              | F08              |
| 23911-VA2-0000              | E16              | 28251-VA2-0000              | E18              | 33461-VD3-0001              | F03              | 38200-SA1-0000              | F21              | 43410-M3B-0001              | F08              |
| 24211-VA2-0001              | E17              | 28262-A01-A000              | E18              | 33462-VD3-0000              | F03              | 38306-SB1-000               | F21              | 43450-SAH-0000              | F15              |
| 24261-VA2-0000              | E17              | 28271-121-6900              | E18              | 33602-SA5-0001              | F19              |                             |                  | 43550-SB1-0000              | F15              |
| 24263-M8Q-0000              | E17              | 28281-035-0180              | E18              | 33652-SA5-0001              | F19              | <b>40000</b>                |                  | 44301-VA5-0001              | F07              |
| 24301-VA2-0002              | E17              | 28300-SB7-0000(X)           | F14              | 33700-SA5-0001              | F19              | 4051A-SA5-0000              | F16              | 44311-VVB-0000              | F07              |
| 24305-VA2-0001              | E16              | 2830A-SB7-0000              | F14              | 33701-SA5-0001              | F19              | 40543-VAD-000               | F08              | 44600-SAH-010               | F07              |
| 24306-VA2-0000              | E16              | 28311-SB7-0000(X)           | F14              | 33702-SA5-0000              | F19              | 40543-VAD-000               | F09              | 44620-VA1-0000              | F07              |
| 24320-VA2-0000              | E17              |                             |                  | 33705-SA5-0000              | F19              | 4054A-VAD-0000              | F08              | 44680-VA1-000               | F07              |
| 24331-VA2-0000              | E14              | <b>30000</b>                |                  | 33741-E51-0001              | F19              | 4054A-VAD-0000              | F09              | 44701-SAH-0001-VN           | F07              |
| 24411-VA2-0001              | E17              | 30400-SA5-0000              | F21              | 34600-SA1-0000              | F21              | 40591-SA5-0001              | F16              | 44710-SAH-0000              | F07              |
| 24421-VA2-0000              | E17              | 30400-SA5-0000              | F21              | 34901-SA5-0000              | F01              | 41201-SAB-0000              | F09              | 44800-VA9-0000              | F07              |
| 24422-VA2-0000              | E17              | 30500-SA5-0000              | F21              | 34905-M9Q-0000              | F03              | 41241-VDA-0001              | F09              | 44803-VA1-0000-M1(X)        | F07              |
| 24430-VA2-0002              | E17              | 30700-M8Q-0000              | F21              | 34905-M9Q-0000              | F19              | 42242-SA1-0000              | F15              | 44805-VA1-0000-M1(X)        | F07              |
| 24435-VA2-0001              | E17              | 3111A-VA2-0003              | E11              | 34906-M9P-0000              | F19              | 42246-SA1-0000              | F15              | 44806-VA1-0001-M1(X)        | F07              |
| 24610-VA2-3002              | E17              | 31120-VA2-0003              | E11              | 34908-M9Q-0000              | F19              | 42301-SAE-0000              | F09              | 44807-VA1-000               | F07              |
| 24630-VA2-0003              | E17              | 31141-VA2-0000              | E11              | 35010-SA5-0000              | F03              | 42304-SAE-0000              | F09              | 44809-VA1-0000-M1(X)        | F07              |

**BAÛNG TRA MA SỐ**  
**PART NO. INDEX**

| Mã số phụ tùng<br>Part. No. | Số thứ tự<br>No. | Mã số phụ tùng<br>Part. No. | Số thứ tự<br>No. | Mã số phụ tùng<br>Part. No. | Số thứ tự<br>No. | Mã số phụ tùng<br>Part. No. | Số thứ tự<br>No. | Mã số phụ tùng<br>Part. No. | Số thứ tự<br>No. |
|-----------------------------|------------------|-----------------------------|------------------|-----------------------------|------------------|-----------------------------|------------------|-----------------------------|------------------|
| 44820-VA9-000               | F07              | 5061A-VB4-0002(X)           | F14              | <b>60000</b>                |                  | 77226-M3F-0000              | F04              | 87134-SAH-0003-T1           | F24              |
| 44830-SA5-0000              | F01              | 50661-VB4-0000              | F14              | 61100-VD3-0001-KB           | F04              | 77226-M3F-0000              | F18              | 87135-SAH-0004-T1           | F24              |
| 45100-SAB-0000-VN           | F02              | 50713-SA1-0000              | F16              | 61200-VD3-0003              | F04              | 77230-SA5-0000              | F22              | 87136-SAH-0004-T1           | F24              |
| 45105-VA1-0000              | F02              | 50714-SA5-0000              | F16              | 61201-M3G-0000-A            | F04              | 77232-F3C-0002              | F18              | 87505-X01-0001-L1           | F23              |
| 45121-VA1-0000              | F07              | 50830-SAE-0001              | F16              | 61251-SA1-0000              | F16              | 77239-SA5-0000              | F18              | 87508-VR3-0000              | F23              |
| 45126-SAR-0000              | F02              | 50840-SAE-0001              | F16              | 64000-SAH-0100-KCS          | F18              | 77240-SA5-0001              | F22              | 87510-KAG-0000              | F23              |
| 4512B-ADA-0000              | F08              | 51400-VAG-0000              | F05              | 64100-SA5-0000              | F06              |                             |                  | 87512-VA2-0000              | F23              |
| 45133-A10-0000              | F08              | 51500-VAG-0000              | F05              | 64301-SAF-0000-KB           | F06              | <b>80000</b>                |                  | 88110-SA5-9000              | F02              |
| 45134-M9Q-0000              | F08              | 51711-SB1-0000              | F05              | 64302-SAF-0000-KB           | F06              | 80100-SA5-0000              | F19              | 88120-SA5-9000              | F02              |
| 45156-VD3-0003              | F05              | 51712-SB1-0000              | F05              | 64303-SA5-0002-RB           | F06              | 80152-SA5-0000              | F18              | 89010-M51-0000-OA           | F25              |
| 45157-VA1-0001              | F05              | 51713-SB1-0000              | F05              | 64304-SA5-0002-RB           | F06              | 80200-SA5-0001              | F19              |                             |                  |
| 45451-N02-0000              | F04              | 52100-SAE-0001-IC           | F16              | 64304-X01-0000              | F06              | 81200-SA5-9000              | F20              | <b>90000</b>                |                  |
| 45500-VD3-0000              | F02              | 52181-A08-3000              | F16              | 64304-X01-0000              | F18              | 81204-H6T-0000              | F20              | 90002-VA2-0000              | E09              |
| 4550A-SAR-0001-VN           | F02              | 52400-SAE-0002              | F17              | 64304-X01-0000              | F19              | 83400-SA5-0000              | F19              | 90012-M9Q-0000              | E03              |
| 46500-SA5-0001              | F15              | 53100-SAH-0001              | F03              | 64305-SA5-A000              | F06              | 83500-SA5-0004-KB           | F18              | 90031-VA1-0002              | E14              |
| 46513-SA1-0000              | F15              | 53140-VAH-0000              | F02              | 64306-X01-0000              | F18              | 83550-SA5-0000-IF           | F18              | 90032-VA1-0002              | E14              |
| 47104-SB1-0000              | F03              | 53166-VAH-0000              | F02              | 64306-X01-0000              | F19              | 83551-SB1-0000              | F22              | 90071-M8Q-0000              | E17              |
|                             |                  | 53167-H09-0001              | F02              | 64307-SA5-A000              | F06              | 83600-SA5-0004-KB           | F18              | 90081-035-0006              | E04              |
| <b>50000</b>                |                  | 53168-H09-0001              | F02              | 64310-SAS-0002-RB           | F04              | 83650-SA5-0000-IF           | F18              | 90081-VA2-0000              | E02              |
| 50100-SAE-0000              | F22              | 53176-M9P-0000              | F02              | 64311-SAS-0001              | F04              | 87000-SAH-0100-T1           | F24              | 90081-VA2-0000              | E05              |
| 50306-VS1-0000              | F05              | 53205-SAF-0003-KB           | F03              | 64312-SAU-0000-KB           | F04              | 87121-SAH-0004-T1           | F24              | 90083-A08-0000              | E04              |
| 50320-SA5-0000              | F22              | 53206-SAF-0001              | F03              | 65311-SA1-0000              | F16              | 87122-SAH-0004-T1           | F24              | 90084-M8Q-0000-IC           | E10              |
| 50322-SA5-0000              | F22              | 5320A-SAR-000               | F05              |                             |                  | 87123-H85-0000              | F04              | 90087-M8Q-0000-IC           | E10              |
| 50326-SA5-0001-KB           | F18              | 5320B-SA6-0000              | F05              | <b>70000</b>                |                  | 87123-SA5-0002-KB           | F18              | 9008A-M8Q-0000              | E10              |
| 50500-SA6-0000              | F15              | 53212-VA3-0000              | F05              | 75581-M9Q-0001              | F18              | 87125-SAH-0001-T1           | F24              | 9008B-M8Q-0000              | E10              |
| 50520-SA1-0001              | F15              | 53214-X04-0000              | F05              | 77200-SAH-0003              | F10              | 87126-SAH-0001-T1           | F24              | 90101-VD3-0001              | F01              |
| 50521-SA1-0000              | F15              | 53215-X04-0001              | F05              | 77206-M51-0000              | F10              | 87127-SAH-0003-T1           | F24              | 90104-VA1-0000              | F03              |
| 50524-SA1-0000              | F15              | 53220-VA3-0001              | F05              | 77210-SAH-0003(X)           | F10              | 87131-SAH-0000-T1           | F24              | 90104-VA1-0000              | F18              |
| 50530-VA2-0001              | F14              | 54207-SB1-0000              | F07              | 77211-SAE-0000              | F10              | 87132-SAH-0000-T1           | F24              | 90105-M40-0000              | F03              |
| 50610-SAE-0001              | F14              |                             |                  | 77212-SAE-0000              | F10              | 87133-SAH-0004-T1           | F24              | 90105-VA1-0001              | F05              |

**BAÛNG TRA MA SỐA**  
**PART NO. INDEX**

| Mã số phụ tùng<br>Part. No. | Số thứ tự<br>No. | Mã số phụ tùng<br>Part. No. | Số thứ tự<br>No. | Mã số phụ tùng<br>Part. No. | Số thứ tự<br>No. | Mã số phụ tùng<br>Part. No. | Số thứ tự<br>No. | Mã số phụ tùng<br>Part. No. | Số thứ tự<br>No. |
|-----------------------------|------------------|-----------------------------|------------------|-----------------------------|------------------|-----------------------------|------------------|-----------------------------|------------------|
| 90106-TAA-0001              | F03              | 90344-SA1-0000              | F22              | 90651-T36-0000              | F01              | 91318-VA2-0000              | E12              | 93903-34320-00              | F06              |
| 90108-B06-0001              | F14              | 90401-M3G-0000              | E07              | 90702-M8Q-0000              | E03              | 92101-06010-OH              | E16              | 93903-34320-00              | F18              |
| 90110-GZ0-000A              | F06              | 90405-VA2-0000              | E04              | 90702-VA2-000               | E05              | 92101-06020-0A              | F14              | 93903-34480-00              | F03              |
| 90110-GZ0-000A              | F18              | 90407-SB1-0000              | E14              | 90702-VA2-000               | E06              | 92101-06028-OH              | F14              | 93903-35180-00              | F03              |
| 90111-M9Q-9000              | F16              | 90431-M3G-0001              | E07              | 90702-VA2-000               | E09              | 92101-08020-0A              | F14              | 93903-35220-00              | F01              |
| 90111-VA2-0000              | F19              | 90432-SB1-0000              | E07              | 90702-VA2-000               | E10              | 92101-08028-0A              | F16              | 93903-35220-00              | F06              |
| 90111-VA2-0000              | F22              | 90432-SB1-0000              | E08              | 90703-HC4-0000              | E14              | 92101-08032-0A              | F09              | 93903-44480                 | F03              |
| 90112-M67-0000              | F16              | 90434-M3G-0000              | E07              | 90741-M8Q-0000              | E15              | 92700-A02-0001              | E02              | 93903-44480                 | F04              |
| 90115-VA3-0000              | F03              | 90441-M8Q-0000              | E04              | 90753-029-003A              | F09              | 92800-12000                 | E14              | 93903-44480                 | F06              |
| 90115-VA3-0000              | F18              | 90442-VA2-0000              | E01              | 91001-M36-0001              | E15              | 92812-10000                 | F16              | 93903-44480                 | F18              |
| 90116-SA1-0000              | F16              | 90443-VA2-0000              | E01              | 91002-VA2-0000              | E15              | 93404-06012-00              | F18              | 94001-06000-00              | F08              |
| 90117-SA1-0000              | F16              | 90444-VA2-0000              | E09              | 91021-148-0040              | E06              | 93404-06016-00              | F19              | 94001-06000-00              | F09              |
| 90118-SA1-0000              | F16              | 90452-VA2-0000              | E16              | 91101-M3G-0000              | E07              | 93500-05006-0A              | E11              | 94001-10000-0S              | F16              |
| 90119-SA1-0000              | F16              | 90452-VA2-0000              | E18              | 91101-M8Q-0000              | E12              | 93500-05008-0A              | E07              | 94001-10000-0S              | F17              |
| 90122-VA1-0000              | F02              | 90454-B04-0002              | E18              | 91201-VA2-0000              | E12              | 93500-05008-0A              | F13              | 94002-10000-0S              | F16              |
| 90127-M8Q-0000              | F08              | 90455-M3G-0000              | E07              | 91202-A01-0000              | E12              | 93500-05010-0A              | E11              | 94002-10080-0S              | F14              |
| 90145-MS9-6112              | F02              | 90461-VA2-0001              | E01              | 91202-VA2-0000              | E06              | 93500-05016-OH              | F21              | 94021-10000                 | F17              |
| 90164-X01-0002              | F03              | 90461-VA2-0001              | E04              | 91203-VA2-0000              | E16              | 93500-05022-00              | F02              | 94030-08000-00              | E06              |
| 90186-VA6-0001              | F20              | 90461-VA2-0001              | E16              | 91208-VA2-0000              | E17              | 93600-06010-0A              | E06              | 94030-08000-00              | F09              |
| 90201-VA2-0002              | E01              | 90462-VA2-0000              | E16              | 91252-030-003A              | F07              | 93600-06016-0A              | E12              | 94050-05080-00              | F19              |
| 90206-001-0007              | E03              | 90463-VA2-0000              | E16              | 91258-410-0131              | F07              | 93891-05022-07              | F07              | 94050-06000-00              | F08              |
| 90231-M8Q-0000              | E07              | 90464-VA2-0000              | E08              | 91301-VA2-0000              | E14              | 93891-06016-07              | F22              | 94050-06080                 | F10              |
| 90231-VA2-0000              | E08              | 90479-X01-0000              | E17              | 91302-M9Q-0000              | E01              | 93901-24310                 | F12              | 94050-06080                 | F11              |
| 90302-SA4-003B              | F03              | 90481-035-0001              | E04              | 91302-VA2-0000              | E12              | 93901-34320                 | F19              | 94050-08000                 | F08              |
| 90302-SA4-003B              | F04              | 90485-A08-0001              | E06              | 91303-M2Q-0000              | E10              | 93903-24220-10              | F03              | 94050-08000                 | F16              |
| 90302-SA4-003B              | F06              | 90545-300-000E              | F02              | 91305-028-1583              | E02              | 93903-24220-10              | F18              | 94050-10080-00              | F03              |
| 90302-SA4-003B              | F18              | 90601-A08-0001              | E16              | 91307-B06-0000              | E06              | 93903-24280                 | F04              | 94050-12000                 | E11              |
| 90306-SB1-0000              | F09              | 90603-A05-0000(X)           | E07              | 91308-M9Q-0000              | E02              | 93903-24380                 | F18              | 94101-05000                 | F13              |
| 90308-M36-0000              | F13              | 90605-A08-0002              | E16              | 91308-VA2-0000(X)           | E10              | 93903-25410                 | F12              | 94101-05000                 | F15              |
| 90309-M9Q-0000              | F22              | 90605-A08-0002              | E18              | 91312-A01-A001              | E06              | 93903-34320-00              | F04              | 94101-06000                 | F08              |

PRICE SHOWN IS PER PIECE. PRODUCT IMAGE PRICES ARE APPROXIMATE GUIDE ONLY.  
PRICES SHOWN ARE SUBJECT TO CHANGE WITHOUT PRIOR NOTICE.

**BAÛNG TRA MÃ SỐ**  
**PART NO. INDEX**

| Mã số phụ tùng<br>Part. No. | Số thứ tự<br>No. | Mã số phụ tùng<br>Part. No. | Số thứ tự<br>No. | Mã số phụ tùng<br>Part. No. | Số thứ tự<br>No. | Mã số phụ tùng<br>Part. No. | Số thứ tự<br>No. | Mã số phụ tùng<br>Part. No. | Số thứ tự<br>No. |
|-----------------------------|------------------|-----------------------------|------------------|-----------------------------|------------------|-----------------------------|------------------|-----------------------------|------------------|
| 94101-06000                 | F09              | 95301-08100-00              | F22              | 96001-06040-00              | E06              |                             |                  |                             |                  |
| 94101-06000                 | F16              | 95301-08110-00              | F22              | 96001-06050-00              | E10              |                             |                  |                             |                  |
| 94101-08000                 | F08              | 95701-06018-07              | E04              | 96001-06050-00              | E13              |                             |                  |                             |                  |
| 94101-08000                 | F16              | 95701-06022-08              | E08              | 96001-06050-00              | E14              |                             |                  |                             |                  |
| 94101-10000-00              | F17              | 95701-06032-00              | F08              | 96001-06060-08              | E14              |                             |                  |                             |                  |
| 94101-12000-00              | F17              | 95701-06035-00              | E09              | 96001-06065-00              | E06              |                             |                  |                             |                  |
| 94103-08000                 | F20              | 95701-06040-00              | E09              | 96001-06065-00              | E14              |                             |                  |                             |                  |
| 94108-11000-00              | F09              | 95701-06110-00              | E01              | 96001-06070-08              | E10              |                             |                  |                             |                  |
| 94111-05000                 | F13              | 95801-06012-00              | F11              | 96001-06080-00              | E06              |                             |                  |                             |                  |
| 94111-06000-00              | F08              | 95801-06012-00              | F12              | 96100-60000-00              | E08              |                             |                  |                             |                  |
| 94111-06000-00              | F09              | 95801-06012-00              | F21              | 96100-60010-00              | E16              |                             |                  |                             |                  |
| 94111-08000                 | F14              | 95801-06012-00              | F22              | 96100-62010-00              | E16              |                             |                  |                             |                  |
| 94111-10000-00              | F08              | 95801-06016-08              | F18              | 96100-62030-00              | E16              |                             |                  |                             |                  |
| 94111-10000-00              | F16              | 95801-06020-00              | F04              | 96100-62030-00              | F09              |                             |                  |                             |                  |
| 94201-16150                 | F16              | 95801-06020-00              | F19              | 96100-69050-00              | E03              |                             |                  |                             |                  |
| 94201-20151                 | F15              | 95801-08016-08              | F11              | 96120-69020-10              | E03              |                             |                  |                             |                  |
| 94201-20151                 | F16              | 95801-08016-08              | F16              | 96140-60010-00              | E06              |                             |                  |                             |                  |
| 94201-30280                 | F15              | 95801-08020-00              | F20              | 96140-63010-10              | F07              |                             |                  |                             |                  |
| 94251-08400                 | F08              | 95801-VD7-0000              | F07              | 96140-63010-10              | F09              |                             |                  |                             |                  |
| 94303-03050                 | E15              | 96001-06010-08              | E12              | 9621A-06000-00              | F05              |                             |                  |                             |                  |
| 94504-03018(X)              | E06              | 96001-06010-08              | F05              | 96220-30085                 | E17              |                             |                  |                             |                  |
| 94510-16000-00              | E18              | 96001-06012-08              | E10              | 96220-30158                 | E09              |                             |                  |                             |                  |
| 94540-05018                 | E09              | 96001-06016-00              | E10              | 96700-06016-00              | E17              |                             |                  |                             |                  |
| 94540-07010                 | E07              | 96001-06022-02              | E11              |                             |                  |                             |                  |                             |                  |
| 94601-13000-00              | E15              | 96001-06025-00              | E01              |                             |                  |                             |                  |                             |                  |
| 95002-70000(X)              | E14              | 96001-06025-00              | E02              | AC-1201-0001                | E01              |                             |                  |                             |                  |
| 95014-72102-OB              | F14              | 96001-06025-00              | E14              |                             |                  |                             |                  |                             |                  |
| 95015-32001-00              | F15              | 96001-06028-07              | E02              |                             |                  |                             |                  |                             |                  |
| 95015-42000-00              | F15              | 96001-06028-07              | E10              |                             |                  |                             |                  |                             |                  |
| 95015-83000                 | F16              | 96001-06032-08              | E10              |                             |                  |                             |                  |                             |                  |

PRICE SHOWN IS PER PIECE. PRODUCT IMAGE PRICES ARE APPROXIMATE GUIDE ONLY.  
PRICES SHOWN ARE SUBJECT TO CHANGE WITHOUT PRIOR NOTICE.





## COLOR CHART MODEL SAH - SC11M4 - 4

### BẢNG MÀU MODEL SAH

| NO<br>TT | PART NO<br>Mã Linh Kiện | PART NAME<br>Tên Linh Kiện | BK-500C / R-010CA<br>BLACK / RED |       |         | R-010CA / WH-058<br>RED / WHITE |       |         | VBM-2020S / WH-058<br>BLUE / WHITE |       |           |
|----------|-------------------------|----------------------------|----------------------------------|-------|---------|---------------------------------|-------|---------|------------------------------------|-------|-----------|
|          |                         |                            | T1                               | Code  |         | T2                              | Code  |         | T3                                 | Code  |           |
| 1        | 50326-SA5-000           | Battery Cover              | KB                               | BLACK | BK-500C | RB                              | RED   | R-010CA | DH                                 | BLUE  | VBM-2020S |
| 2        | 53205-SAF-000           | Fr. Handle Cover           | KB                               | BLACK | BK-500C | RB                              | RED   | R-010CA | DH                                 | BLUE  | VBM-2020S |
| 3        | 61100-VD3-000           | Fr. Fender A               | KB                               | BLACK | BK-500C | RB                              | RED   | R-010CA | DH                                 | BLUE  | VBM-2020S |
| 4        | 61200-VD3-000           | Fr. Fender B               | KB                               | BLACK | BK-500C | RB                              | RED   | R-010CA | DH                                 | BLUE  | VBM-2020S |
| 5        | 64301-SAF-000           | Right Front Cover          | KB                               | BLACK | BK-500C | RB                              | RED   | R-010CA | DH                                 | BLUE  | VBM-2020S |
| 6        | 64302-SAF-000           | Left Front Cover           | KB                               | BLACK | BK-500C | RB                              | RED   | R-010CA | DH                                 | BLUE  | VBM-2020S |
| 7        | 64303-SA5-000           | Right Main Pipe Cover      | RB                               | RED   | R-010CA | WB                              | WHITE | WH-058  | WB                                 | WHITE | WH-058    |
| 8        | 64304-SA5-000           | Left Main Pipe Cover       | RB                               | RED   | R-010CA | WB                              | WHITE | WH-058  | WB                                 | WHITE | WH-058    |
| 9        | 64310-SAS-000           | Fr. Top Cover              | RB                               | RED   | R-010CA | WB                              | WHITE | WH-058  | WB                                 | WHITE | WH-058    |
| 10       | 64312-SAU-000           | Fr. Top Cover Emblem       | KB                               | BLACK | BK-500C | RB                              | RED   | R-010CA | DH                                 | BLUE  | VBM-2020S |
| 11       | 83500-SA5-000           | Rh. Body Cover             | KB                               | BLACK | BK-500C | RB                              | RED   | R-010CA | DH                                 | BLUE  | VBM-2020S |
| 12       | 83550-SA5-000           | R. Side Plate              | IF                               | GREY  | GY-097  | IF                              | GREY  | GY-097  | IF                                 | GREY  | GY-097    |
| 13       | 83600-SA5-000           | Lh. Body Cover             | KB                               | BLACK | BK-500C | RB                              | RED   | R-010CA | DH                                 | BLUE  | VBM-2020S |
| 14       | 83650-SA5-000           | L. Side Plate              | IF                               | GREY  | GY-097  | IF                              | GREY  | GY-097  | IF                                 | GREY  | GY-097    |
| 15       | 87123-SA5-000           | Rr. Center Cover           | KB                               | BLACK | BK-500C | RB                              | RED   | R-010CA | DH                                 | BLUE  | VBM-2020S |

PRICE SHOWN IS PER PIECE. PRODUCT IMAGE PRICES ARE APPROXIMATE GUIDE ONLY.  
PRICES SHOWN ARE SUBJECT TO CHANGE WITHOUT PRIOR NOTICE.

COLOUR